

WTM503P075LK-HAF

P-Channel Enhancement Mode MOSFET

Features

- Advanced trench cell design
- High speed switch
- Halogen and Antimony Free(HAF), RoHS compliant
- Built-in G-S Protection Diode
- Typical ESD Protection HBM Class 2

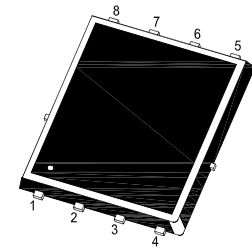
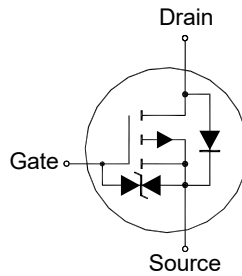

1.Source 2.Source 3.Source 4.Gate
5.Drain 6.Drain 7.Drain 8.Drain
DFN5060 Plastic Package

Classification	Voltage Range(V)
0A	< 125
0B	125 to < 250
1A	250 to < 500
1B	500 to < 1000
1C	1000 to < 2000
2	2000 to < 4000
3A	4000 to < 8000
3B	≥ 8000

Key Parameters

Parameter	Value	Unit
$-V_{(BR)DSS}$	30	V
$R_{DS(ON) Max}$	7.5 @ $-V_{GS} = 10 V$	mΩ
	11.5 @ $-V_{GS} = 4.5 V$	
$-V_{GS(th) typ}$	1.5	V
$Q_g typ$	112 @ $-V_{GS} = 10 V$	nC

Applications

- Portable appliances
- Battery management

Absolute Maximum Ratings (at $T_a = 25^\circ C$ unless otherwise specified)

Parameter	Symbol	Value	Unit	
Drain-Source Voltage	$-V_{DS}$	30	V	
Gate-Source Voltage	V_{GS}	± 20	V	
Drain Current	$-I_D$	$T_c = 25^\circ C$	62	A
		$T_c = 100^\circ C$	39	
Peak Drain Current ¹⁾	$-I_{DM}$	300	A	
Avalanche Current	$-I_{AS}$	58.1	A	
Avalanche Energy ²⁾	E_{AS}	168.8	mJ	
Power Dissipation	P_D	41.1	W	
Operating Junction and Storage Temperature Range	T_J, T_{stg}	- 55 to + 150	°C	

Thermal Characteristics

Parameter	Symbol	Max.	Unit
Thermal Resistance from Junction to Case	$R_{\theta JC}$	3	°C/W
Thermal Resistance from Junction to Ambient ³⁾	$R_{\theta JA}$	39	°C/W

¹⁾ Pulse Test: Pulse Width ≤ 100 μs, Duty Cycle ≤ 2%, Repetitive rating, pulse width limited by junction temperature $T_{J(MAX)} = 150^\circ C$.

²⁾ Limited by $T_{J(MAX)}$, starting $T_J = 25^\circ C$, $L = 0.1 mH$, $R_g = 25 \Omega$, $-I_{AS} = 58.1 A$, $V_{GS} = 10 V$.

³⁾ Device mounted on FR-4 substrate PC board, 2oz copper, with 1-inch square copper plate in still air.

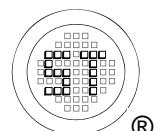

WTM503P075LK-HAF

Characteristics at $T_a = 25^\circ\text{C}$ unless otherwise specified

Parameter	Symbol	Min.	Typ.	Max.	Unit
STATIC PARAMETERS					
Drain-Source Breakdown Voltage at $-I_D = 250 \mu\text{A}$	$-V_{(BR)DSS}$	30	-	-	V
Drain-Source On-State Current at $-V_{DS} = 24 \text{ V}$	$-I_{DSS}$	-	-	1	μA
Gate-Source Leakage Current at $V_{GS} = \pm 20 \text{ V}$	I_{GSS}	-	-	± 10	μA
Gate-Source Threshold Voltage at $V_{DS} = V_{GS}$, $-I_D = 250 \mu\text{A}$	$-V_{GS(th)}$	1	-	2.5	V
Drain-Source On-State Resistance at $-V_{GS} = 10 \text{ V}$, $-I_D = 20 \text{ A}$ at $-V_{GS} = 4.5 \text{ V}$, $-I_D = 15 \text{ A}$	$R_{DS(ON)}$	- -	6 -	7.5 11.5	$\text{m}\Omega$
DYNAMIC PARAMETERS					
Forward Transconductance at $-V_{DS} = 5 \text{ V}$, $-I_D = 20 \text{ A}$	g_{fs}	-	9.1	-	S
Gate resistance at $V_{GS} = 0 \text{ V}$, $V_{DS} = 0 \text{ V}$, $f = 1 \text{ MHz}$	R_g	-	4.4	-	Ω
Input Capacitance at $V_{GS} = 0 \text{ V}$, $-V_{DS} = 15 \text{ V}$, $f = 1 \text{ MHz}$	C_{iss}	-	7150	-	pF
Output Capacitance at $V_{GS} = 0 \text{ V}$, $-V_{DS} = 15 \text{ V}$, $f = 1 \text{ MHz}$	C_{oss}	-	650	-	pF
Reverse Transfer Capacitance at $V_{GS} = 0 \text{ V}$, $-V_{DS} = 15 \text{ V}$, $f = 1 \text{ MHz}$	C_{rss}	-	472	-	pF
Total Gate Charge at $-V_{GS} = 10 \text{ V}$, $-V_{DS} = 15 \text{ V}$, $-I_D = 1 \text{ A}$ at $-V_{GS} = 4.5 \text{ V}$, $-V_{DS} = 15 \text{ V}$, $-I_D = 1 \text{ A}$	Q_g	- -	112 53	- -	nC
Gate-Source Charge at $-V_{GS} = 10 \text{ V}$, $-V_{DS} = 15 \text{ V}$, $-I_D = 1 \text{ A}$	Q_{gs}	-	19	-	nC
Gate-Drain Charge at $-V_{GS} = 10 \text{ V}$, $-V_{DS} = 15 \text{ V}$, $-I_D = 1 \text{ A}$	Q_{gd}	-	14	-	nC
Turn-On Delay Time at $-V_{GS} = 10 \text{ V}$, $-V_{DD} = 15 \text{ V}$, $-I_D = 1 \text{ A}$, $R_g = 3.3 \Omega$	$t_{d(on)}$	-	25	-	ns
Turn-On Rise Time at $-V_{GS} = 10 \text{ V}$, $-V_{DD} = 15 \text{ V}$, $-I_D = 1 \text{ A}$, $R_g = 3.3 \Omega$	t_r	-	10	-	ns
Turn-Off Delay Time at $-V_{GS} = 10 \text{ V}$, $-V_{DD} = 15 \text{ V}$, $-I_D = 1 \text{ A}$, $R_g = 3.3 \Omega$	$t_{d(off)}$	-	76	-	ns
Turn-Off Fall Time at $-V_{GS} = 10 \text{ V}$, $-V_{DD} = 15 \text{ V}$, $-I_D = 1 \text{ A}$, $R_g = 3.3 \Omega$	t_f	-	35	-	ns
Body-Diode PARAMETERS					
Drain-Source Diode Forward Voltage at $-I_S = 1 \text{ A}$, $V_{GS} = 0 \text{ V}$	$-V_{SD}$	-	-	1.3	V
Body-Diode Continuous Current	$-I_S$	-	-	62	A
Body-Diode Continuous Current, Pulsed	$-I_{SM}$	-	-	300	A
Body Diode Reverse Recovery Time at $-I_S = 1 \text{ A}$, $di/dt = 100 \text{ A} / \mu\text{s}$	t_{rr}	-	26	-	ns
Body Diode Reverse Recovery Charge at $-I_S = 1 \text{ A}$, $di/dt = 100 \text{ A} / \mu\text{s}$	Q_{rr}	-	19	-	nC

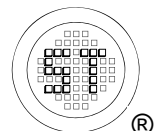

Electrical Characteristics Curves

Fig. 1 Typical Output Characteristics

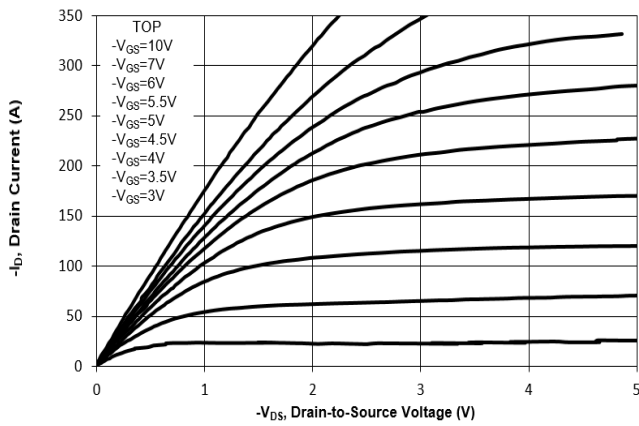

Fig. 2 Typical Transfer Characteristics

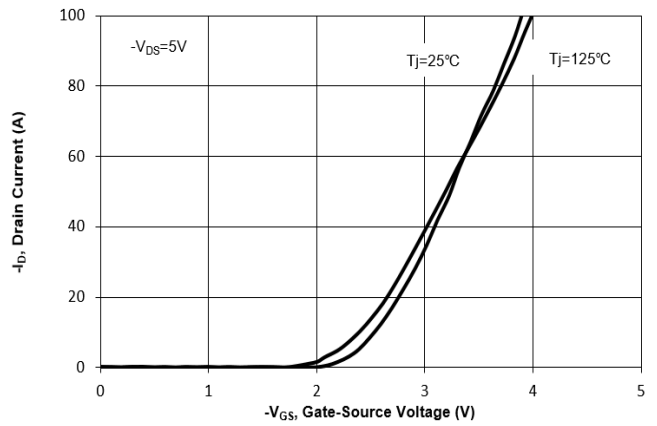

Fig. 3 on-Resistance vs. Drain Current

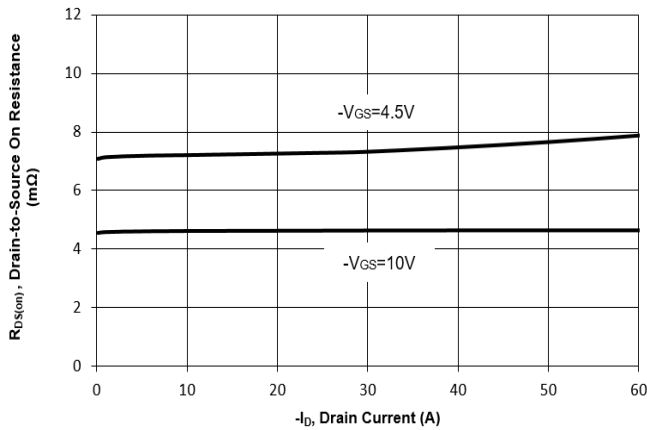

Fig. 4 on-Resistance vs. Gate to Source Voltage

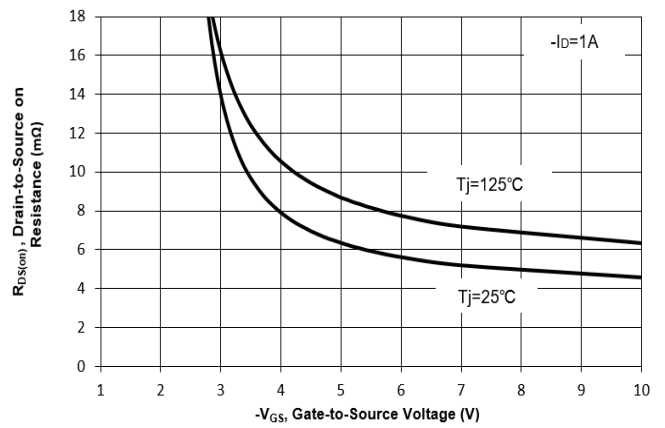

Fig. 5 on-Resistance vs. Tj

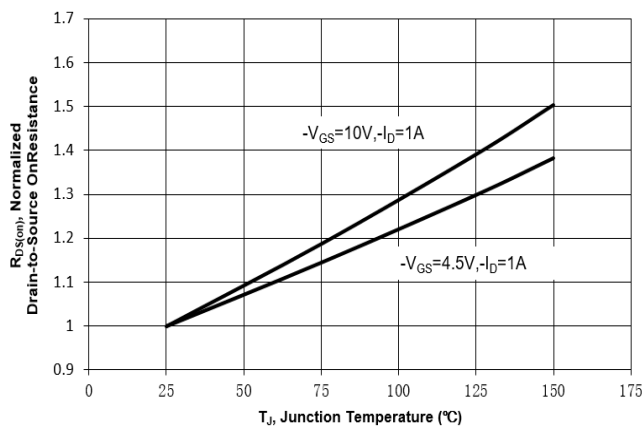
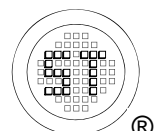
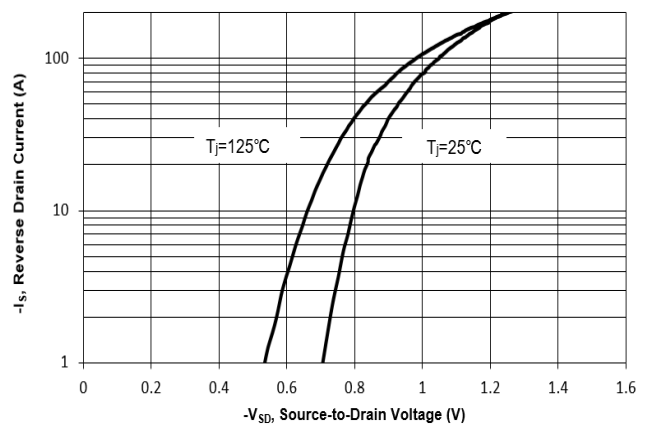

Fig. 6 Typical Body-Diode Forward Characteristics



Electrical Characteristics Curves

Fig. 7 Typical Junction Capacitance

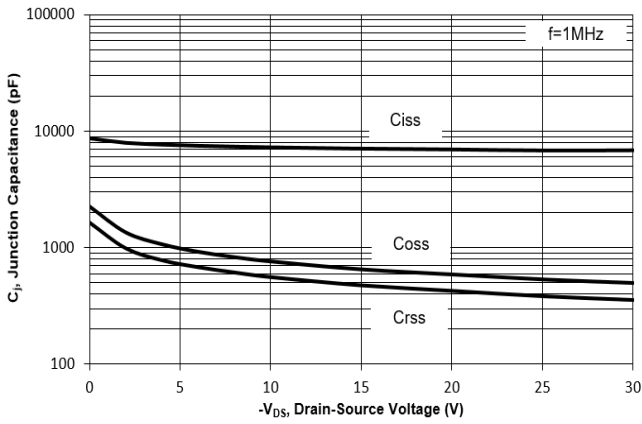

Fig. 8 Drain-Source Leakage Current vs. Tj

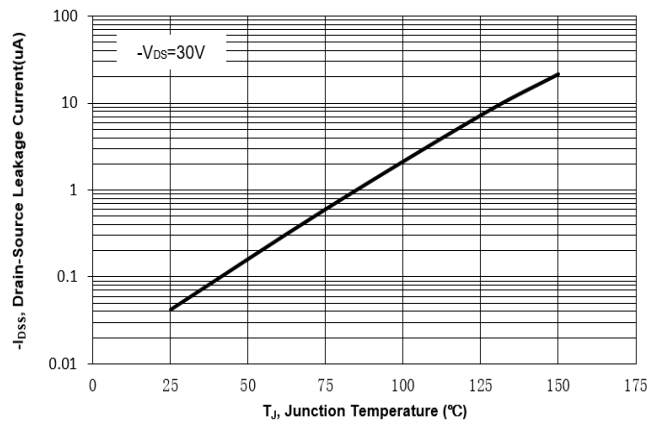

Fig. 9 $V_{(BR)DSS}$ vs. Junction Temperature

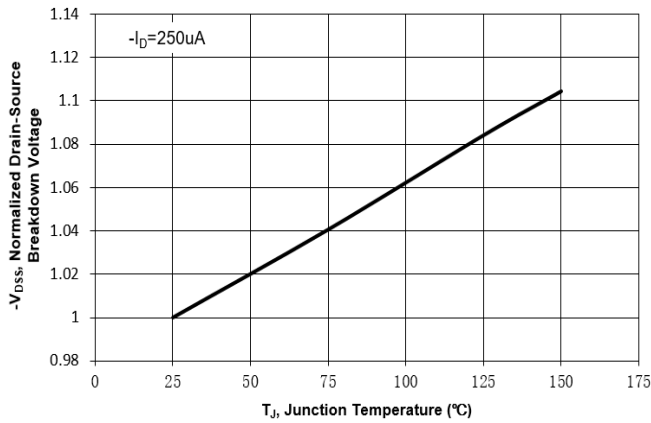

Fig. 10 Gate Threshold Variation vs. Tj

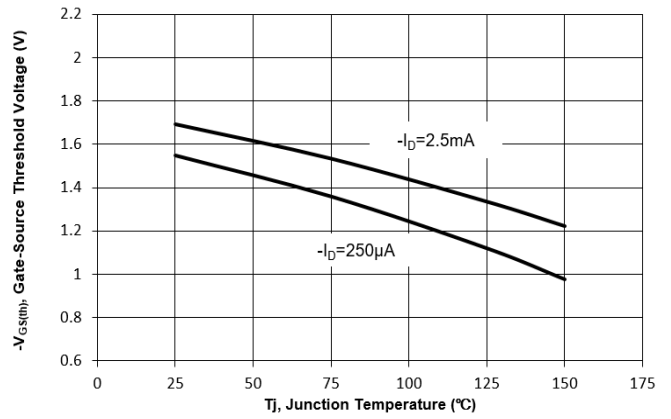

Fig. 11 Gate Charge

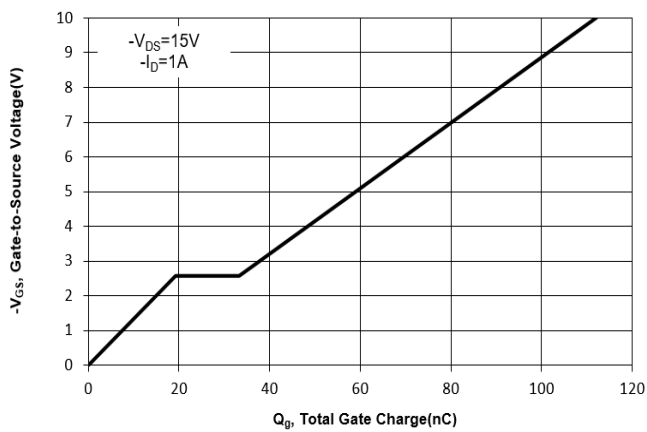
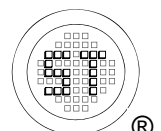
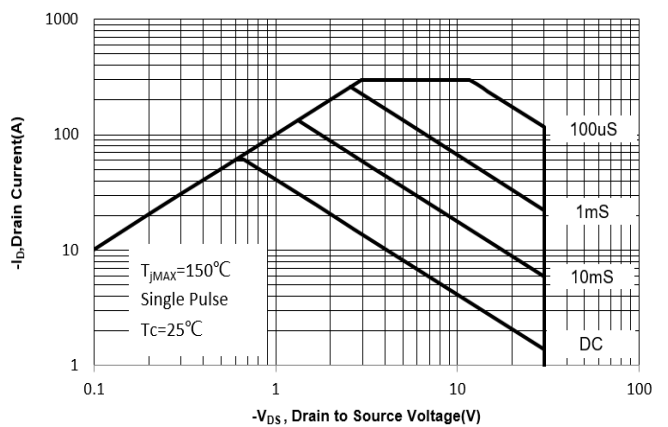

Fig. 12 Safe Operation Area



Electrical Characteristics Curves

Fig. 13 Normalized Maximum Transient Thermal Impedance($Z_{\theta JC}$)

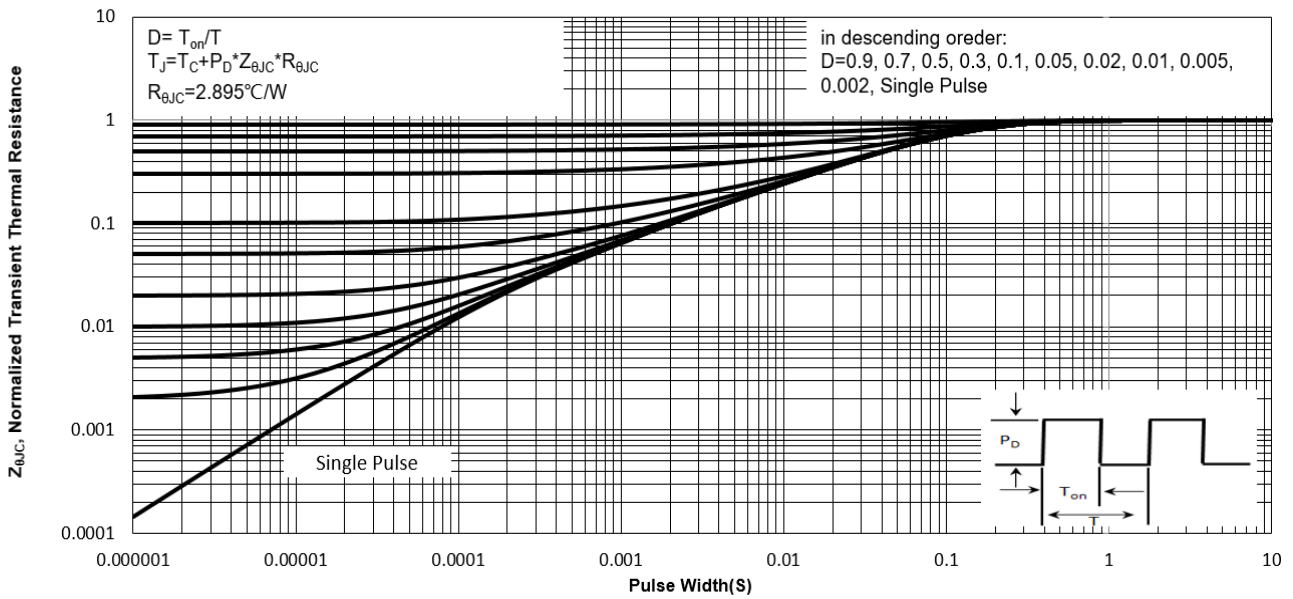
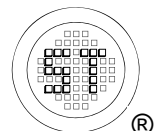
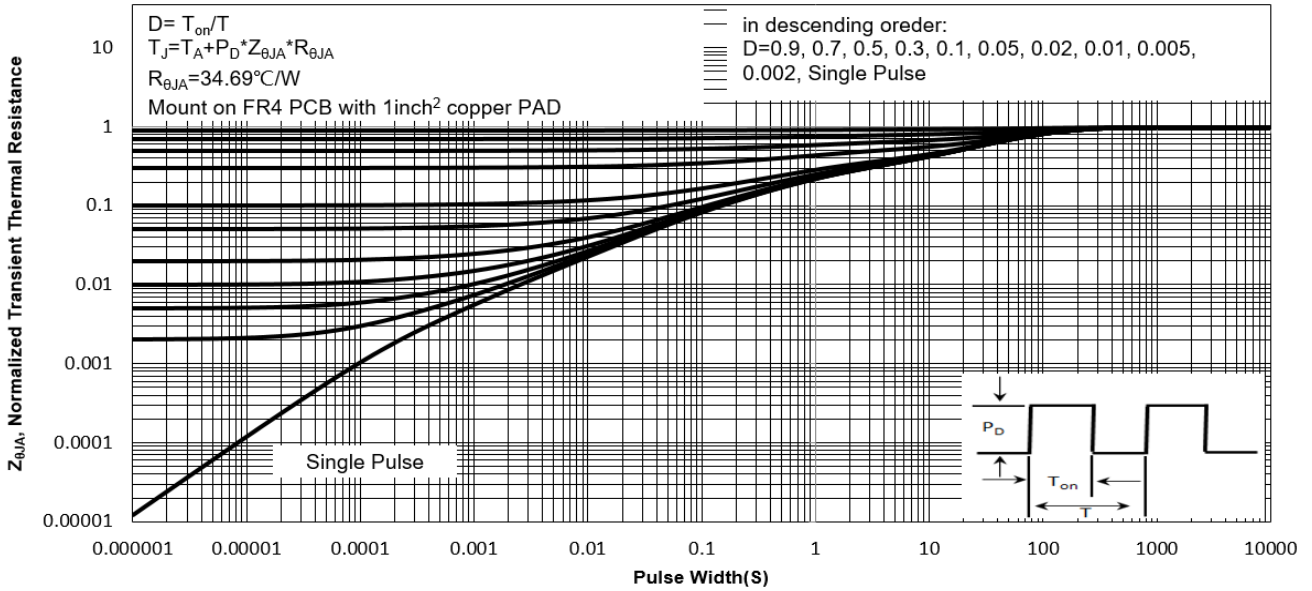

Fig. 14 Normalized Maximum Transient Thermal Impedance($Z_{\theta JA}$)



Test Circuits

Fig.1-1 Switching times test circuit

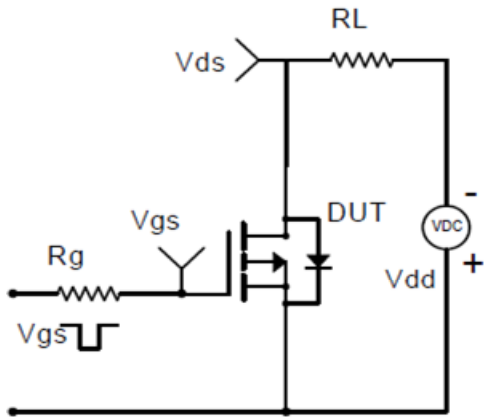

Fig.1-2 Switching Waveform

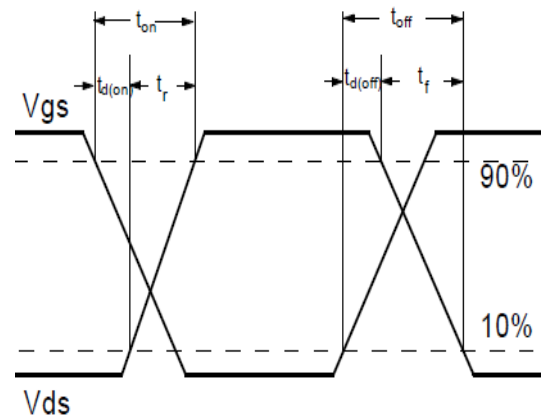

Fig.2-1 Gate charge test circuit

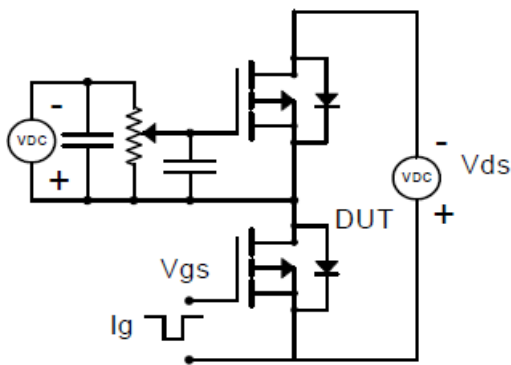

Fig.2-2 Gate charge waveform

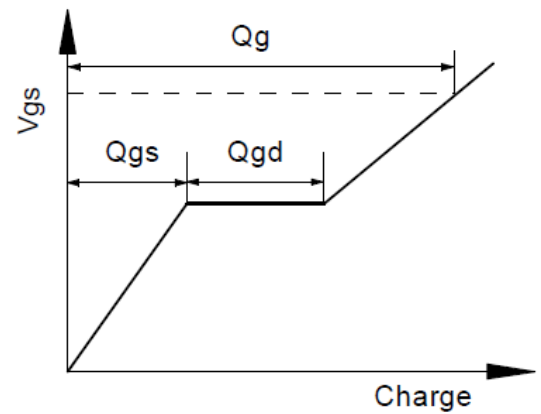

Fig.3-1 Avalanche test circuit

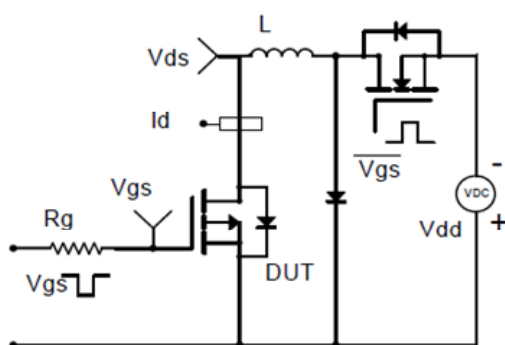
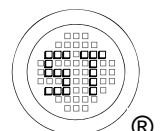
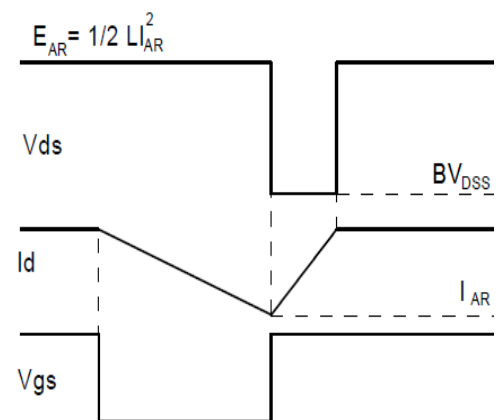

Fig.3-2 Avalanche waveform



WTM503P075LK-HAF

Package Outline Dimensions (Units: mm)

DFN5060

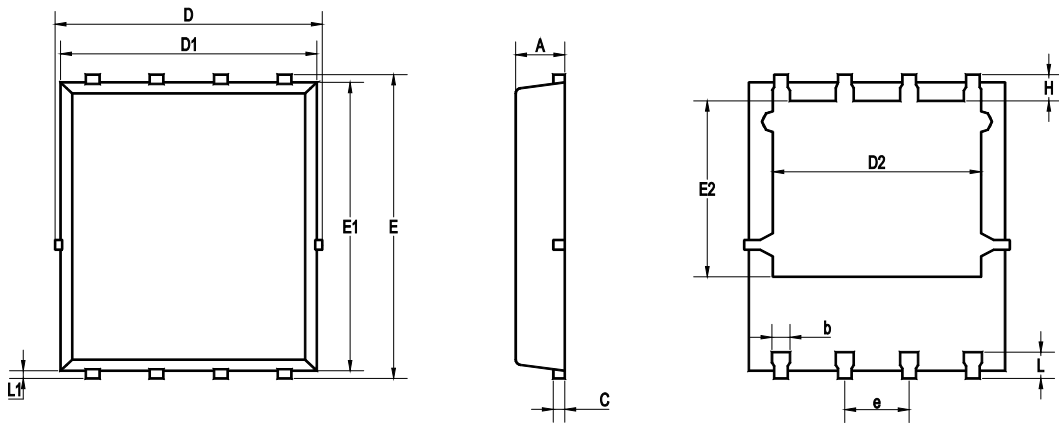

UNIT	A	b	C	D	D1	D2	E	E1	E2	e	L	L1	H
mm	1.12 0.9	0.51 0.33	0.34 0.11	5.26 4.7	5.1 4.7	4.5 3.56	6.25 5.75	6 5.6	3.66 3.18	1.37 1.17	0.71 0.35	0.2 0.06	0.71 0.35

Recommended Soldering Footprint

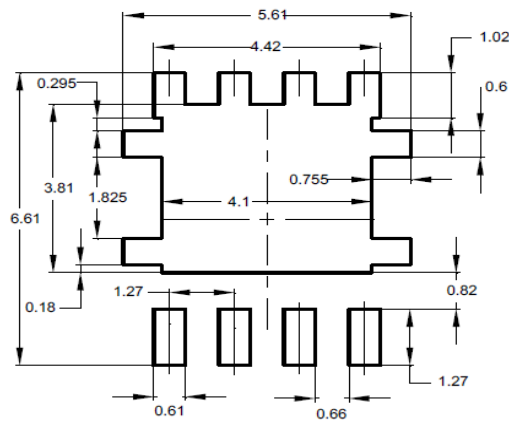

Packing information

Package	Tape Width (mm)	Pitch		Reel Size		Per Reel Packing Quantity
		mm	inch	mm	inch	
DFN5060	12	8 ± 0.1	0.315 ± 0.004	330	13	5,000

Marking information

" TM503P075LK " = Part No.
 " ***** " = Date Code Marking
 Font type: Arial

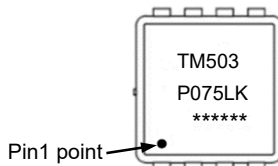

Disclaimer: Our company reserve the right to make modifications, enhancements, improvements, corrections or other changes to improve product design, functions and reliability, anytime without notice.

