

WTM304N160LS-HAF

N-Channel Enhancement Mode MOSFET

Features

- Surface-mounted package
- Low Gate-Source Threshold Voltage
- Halogen and Antimony Free(HAF)
RoHS compliant

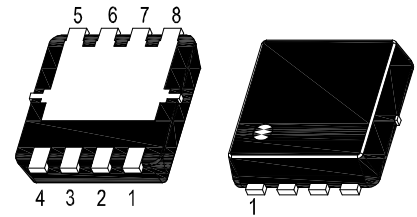
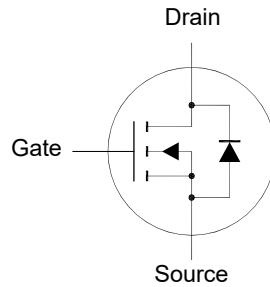

1. Source 2. Source 3. Source 4. Gate
5. Drain 6. Drain 7. Drain 8. Drain
DFN3030 Plastic Package

Key Parameters

Parameter	Value	Unit
BV_{DSS}	40	V
$R_{DS(ON)}$ Max	16 @ $V_{GS} = 10$ V	m Ω
	20 @ $V_{GS} = 4.5$ V	
$V_{GS(th)}$ typ	1.6	V
Q_g typ	22 @ $V_{GS} = 10$ V	nC

Absolute Maximum Ratings (at $T_a = 25^\circ\text{C}$ unless otherwise specified)

Parameter	Symbol	Value	Unit
Drain-Source Voltage	V_{DS}	40	V
Gate-Source Voltage	V_{GS}	± 20	V
Drain Current - Continuous		$T_c = 25^\circ\text{C}$	29
		$T_c = 100^\circ\text{C}$	18
Drain Current Pulsed ¹⁾	I_{DM}	100	A
Avalanche Current	I_{AS}	9.8	A
Single Pulse Avalanche Energy ²⁾	E_{AS}	24	mJ
Power Dissipation	P_D	23.3	W
Operating Junction and Storage Temperature Range	T_J, T_{stg}	- 55 to + 150	$^\circ\text{C}$

Thermal Characteristics

Parameter	Symbol	Max.	Unit
Thermal Resistance from Junction to Case	$R_{\theta JC}$	5.3	$^\circ\text{C}/\text{W}$
Thermal Resistance from Junction to Ambient ³⁾	$R_{\theta JA}$	60	$^\circ\text{C}/\text{W}$

¹⁾ Pulse Test: Pulse Width ≤ 100 μs , Duty Cycle $\leq 2\%$, Repetitive rating, pulse width limited by junction temperature $T_{J(MAX)} = 150^\circ\text{C}$.

²⁾ Limited by $T_{J(MAX)}$, starting $T_J = 25^\circ\text{C}$, $L = 0.5$ mH, $R_g = 25$ Ω , $I_{AS} = 9.8$ A, $V_{GS} = 10$ V.

³⁾ Device Surface Mounted on FR-4 substrate PC board, 2oz copper, with 1-inch square copper plate, in a still air.

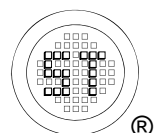

WTM304N160LS-HAF

Characteristics at $T_a = 25^\circ\text{C}$ unless otherwise specified

Parameter	Symbol	Min.	Typ.	Max.	Unit
STATIC PARAMETERS					
Drain-Source Breakdown Voltage at $I_D = 250 \mu\text{A}$	BV_{DSS}	40	-	-	V
Drain-Source Leakage Current at $V_{DS} = 32 \text{ V}$	I_{DSS}	-	-	1	μA
Gate-Source Leakage Current at $V_{GS} = \pm 20 \text{ V}$	I_{GSS}	-	-	± 100	nA
Gate-Source Threshold Voltage at $V_{DS} = V_{GS}, I_D = 250 \mu\text{A}$	$V_{GS(th)}$	1	-	2.5	V
Drain-Source On-State Resistance at $V_{GS} = 10 \text{ V}, I_D = 10 \text{ A}$ at $V_{GS} = 4.5 \text{ V}, I_D = 5 \text{ A}$	$R_{DS(on)}$	- -	12.7 -	16 20	$\text{m}\Omega$
DYNAMIC PARAMETERS					
Forward Transconductance at $V_{DS} = 5 \text{ V}, I_D = 5 \text{ A}$	g_{fs}	-	11.3	-	S
Gate resistance at $V_{GS} = 0 \text{ V}, V_{DS} = 0 \text{ V}, f = 1 \text{ MHz}$	R_g	-	1.2	-	Ω
Input Capacitance at $V_{GS} = 0 \text{ V}, V_{DS} = 20 \text{ V}, f = 1 \text{ MHz}$	C_{iss}	-	1038	-	pF
Output Capacitance at $V_{GS} = 0 \text{ V}, V_{DS} = 20 \text{ V}, f = 1 \text{ MHz}$	C_{oss}	-	83	-	pF
Reverse Transfer Capacitance at $V_{GS} = 0 \text{ V}, V_{DS} = 20 \text{ V}, f = 1 \text{ MHz}$	C_{rss}	-	52	-	pF
Gate charge total at $V_{DS} = 20 \text{ V}, I_D = 10 \text{ A}, V_{GS} = 10 \text{ V}$ at $V_{DS} = 20 \text{ V}, I_D = 10 \text{ A}, V_{GS} = 4.5 \text{ V}$	Q_g	- -	22 10	- -	nC
Gate to Source Charge at $V_{DS} = 20 \text{ V}, I_D = 10 \text{ A}, V_{GS} = 10 \text{ V}$	Q_{gs}	-	4	-	nC
Gate to Drain Charge at $V_{DS} = 20 \text{ V}, I_D = 10 \text{ A}, V_{GS} = 10 \text{ V}$	Q_{gd}	-	4	-	nC
Turn-On Delay Time at $V_{DS} = 20 \text{ V}, I_D = 10 \text{ A}, V_{GS} = 10 \text{ V}, R_g = 3.3 \Omega$	$t_{d(on)}$	-	10	-	ns
Turn-On Rise Time at $V_{DS} = 20 \text{ V}, I_D = 10 \text{ A}, V_{GS} = 10 \text{ V}, R_g = 3.3 \Omega$	t_r	-	21	-	ns
Turn-Off Delay Time at $V_{DS} = 20 \text{ V}, I_D = 10 \text{ A}, V_{GS} = 10 \text{ V}, R_g = 3.3 \Omega$	$t_{d(off)}$	-	10	-	ns
Turn-Off Fall Time at $V_{DS} = 20 \text{ V}, I_D = 10 \text{ A}, V_{GS} = 10 \text{ V}, R_g = 3.3 \Omega$	t_f	-	1.6	-	ns
Body-Diode PARAMETERS					
Drain-Source Diode Forward Voltage at $I_S = 1 \text{ A}, V_{GS} = 0 \text{ V}$	V_{SD}	-	-	1.2	V
Body-Diode Continuous Current	I_S	-	-	29	A
Body-Diode Continuous Current, Pulsed	I_{SM}	-	-	100	A
Body Diode Reverse Recovery Time at $I_S = 10 \text{ A}, di/dt = 100 \text{ A} / \mu\text{s}$	t_{rr}	-	9	-	ns
Body Diode Reverse Recovery Charge at $I_S = 10 \text{ A}, di/dt = 100 \text{ A} / \mu\text{s}$	Q_{rr}	-	4	-	nC

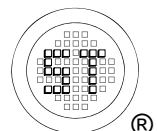

WTM304N160LS-HAF

Electrical Characteristics Curves

Fig. 1 Typical Output Characteristics

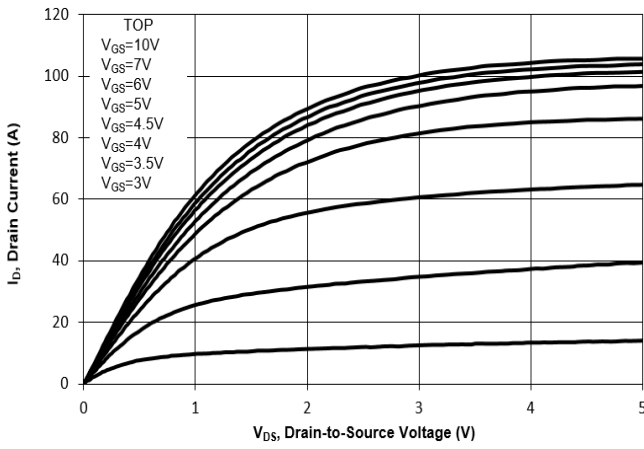

Fig. 2 Typical Transfer Characteristics

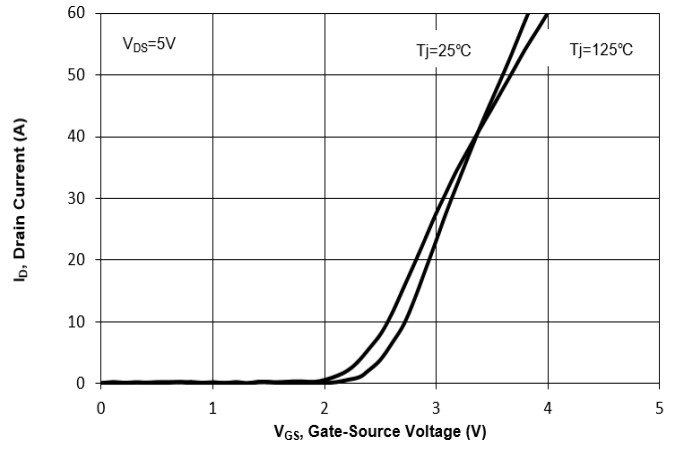

Fig. 3 On-Resistance vs. Drain Current

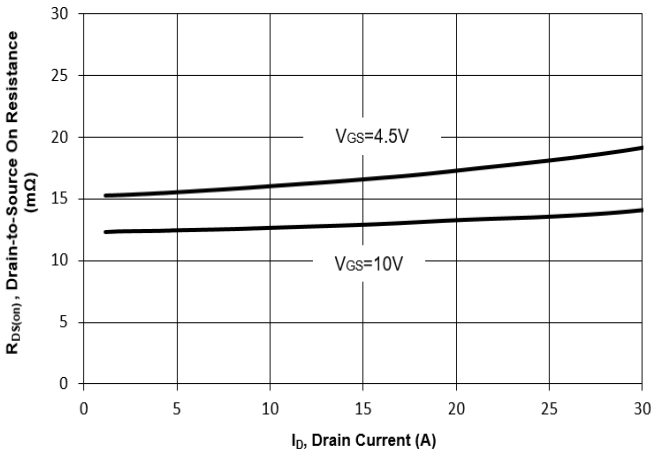

Fig. 4 On-Resistance vs. Gate to Source Voltage

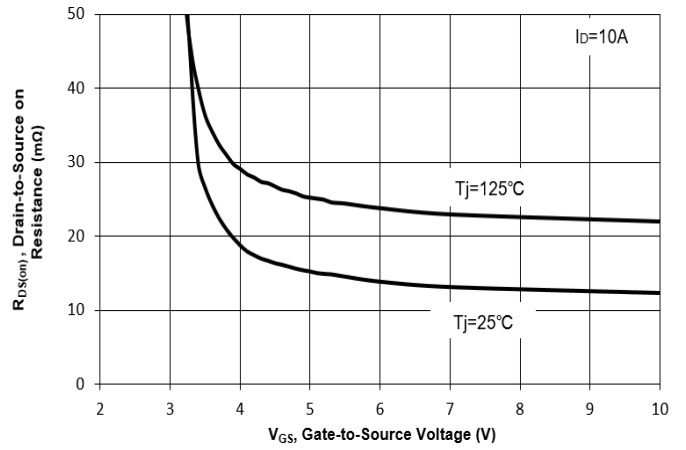

Fig. 5 On-Resistance vs. T_J

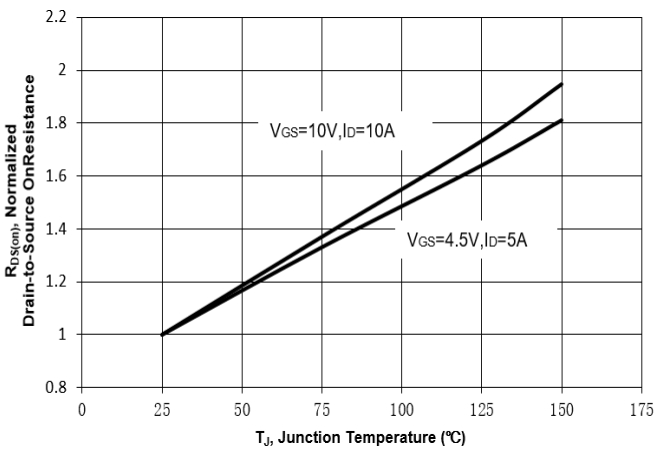
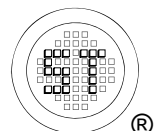
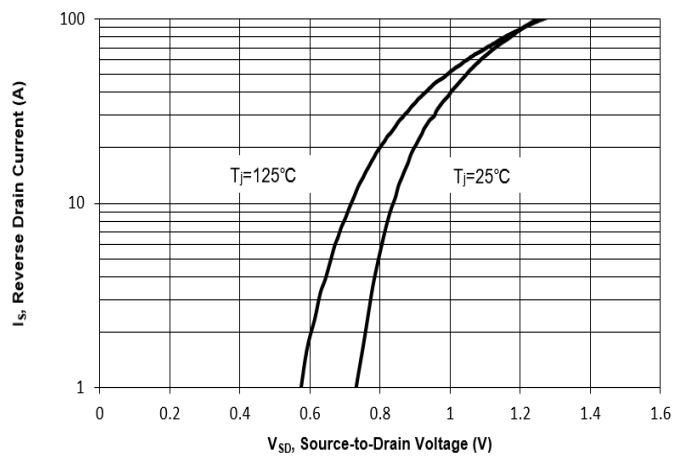

Fig. 6 Typical Body-Diode Forward Characteristics



WTM304N160LS-HAF

Electrical Characteristics Curves

Fig. 7 Typical Junction Capacitance

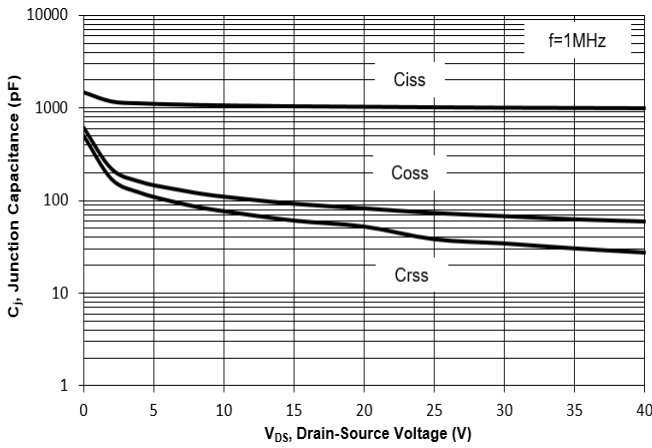

Fig. 8 Drain-Source Leakage Current vs. Tj

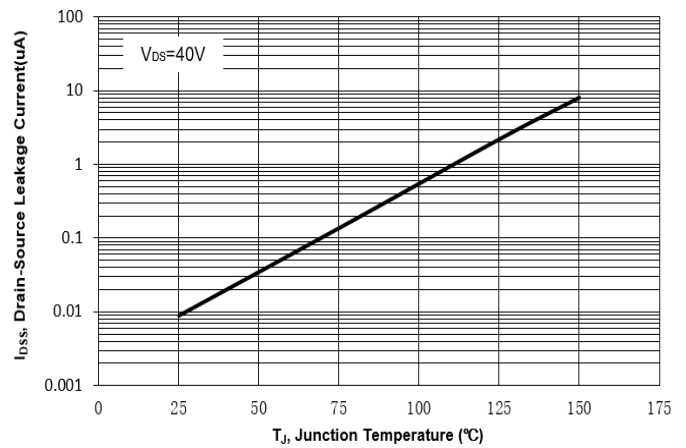

Fig. 9 V(BR)DSS vs. Junction Temperature

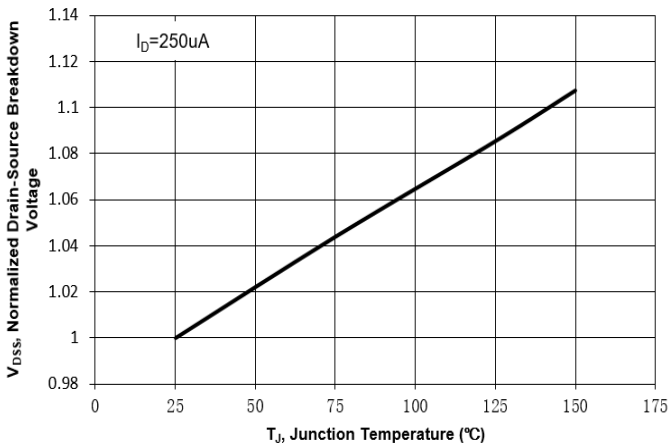

Fig. 10 Gate Threshold Variation vs. Tj

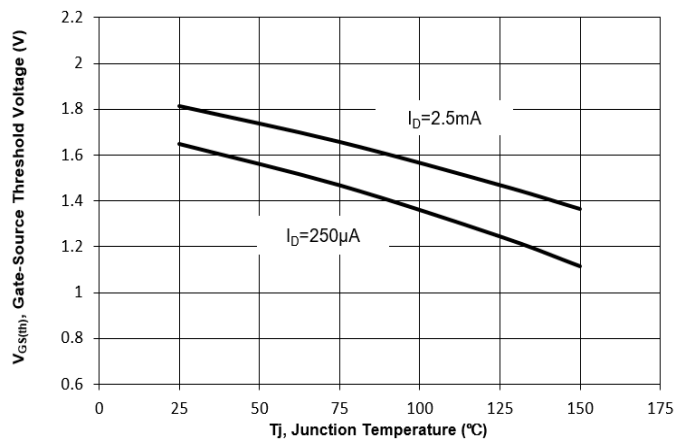

Fig. 11 Gate Charge

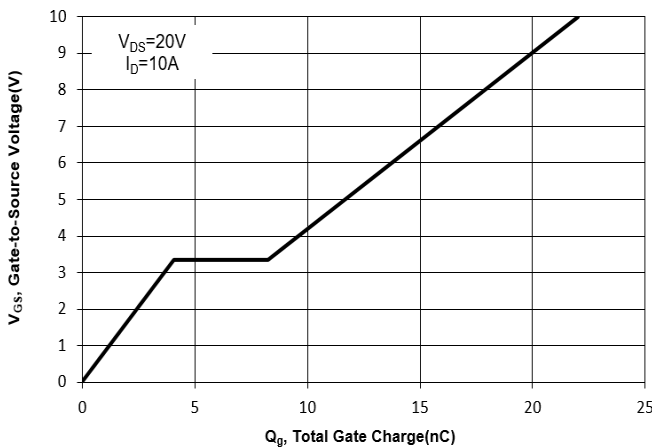
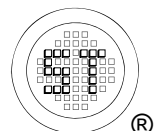
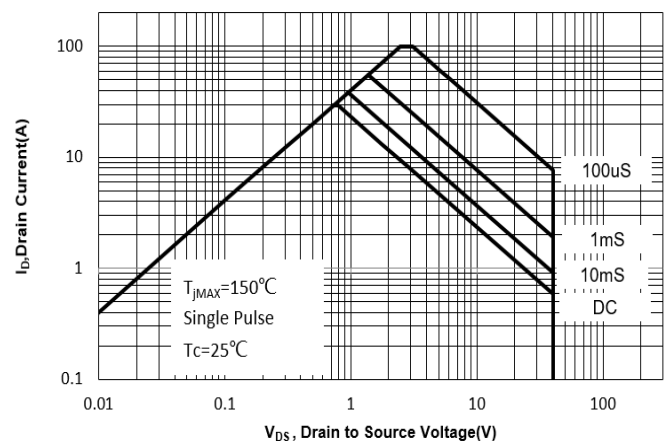

Fig. 12 Safe Operation Area



Electrical Characteristics Curves

Fig.13 Normalized Maximum Transient Thermal Impedance($Z_{\theta JC}$)

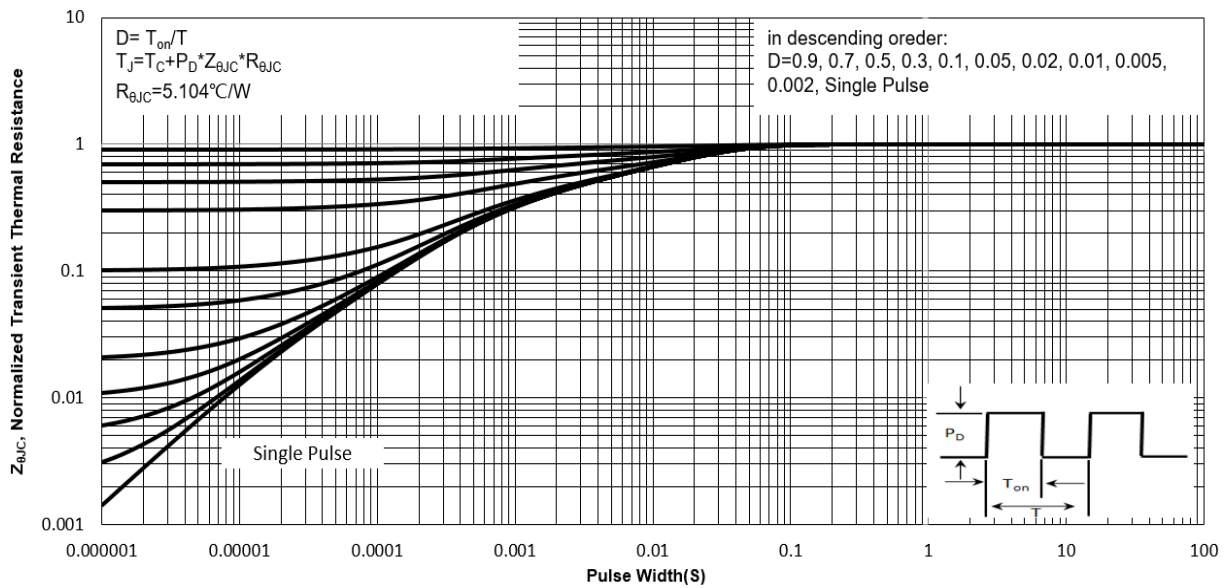
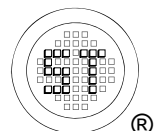
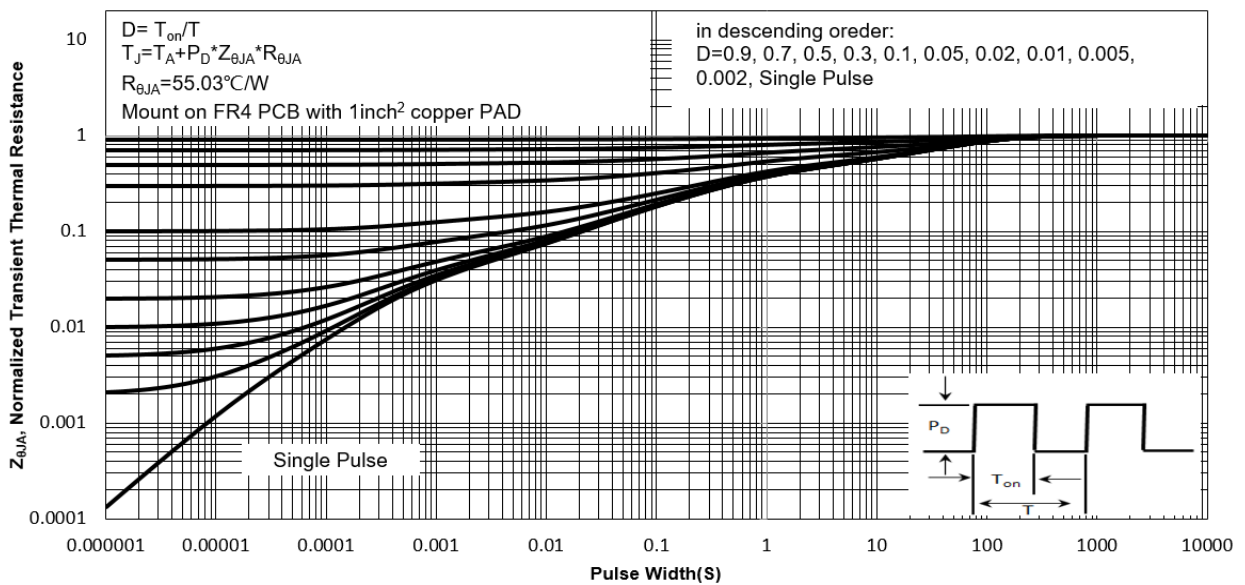

Fig.14 Normalized Maximum Transient Thermal Impedance($Z_{\theta JA}$)



Test Circuits

Fig.1-1 Switching times test circuit

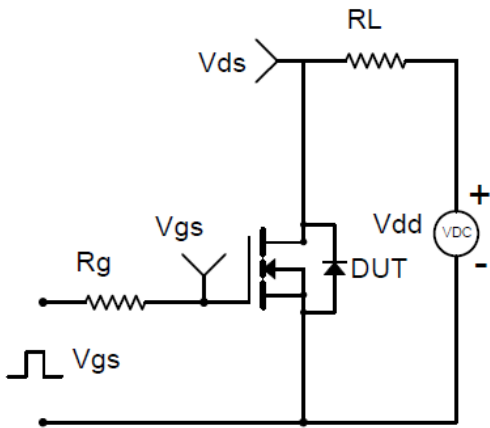

Fig.1-2 Switching Waveform

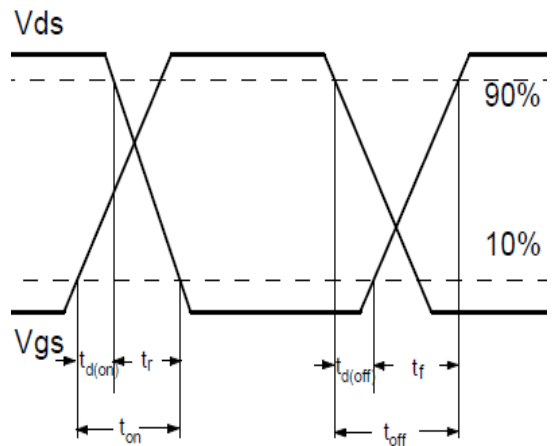

Fig.2-1 Gate charge test circuit

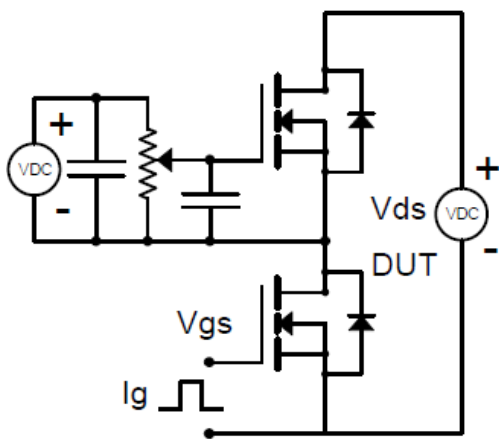

Fig.2-2 Gate charge waveform

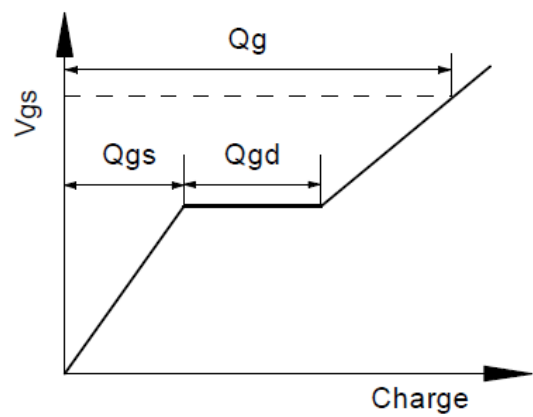

Fig.3-1 Avalanche test circuit

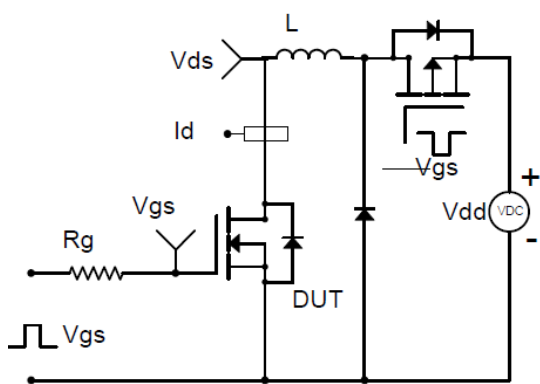
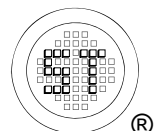
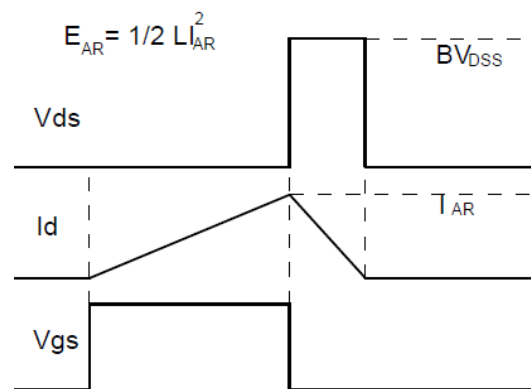

Fig.3-2 Avalanche waveform



WTM304N160LS-HAF

Package Outline Dimensions (Units: mm)

DFN3030

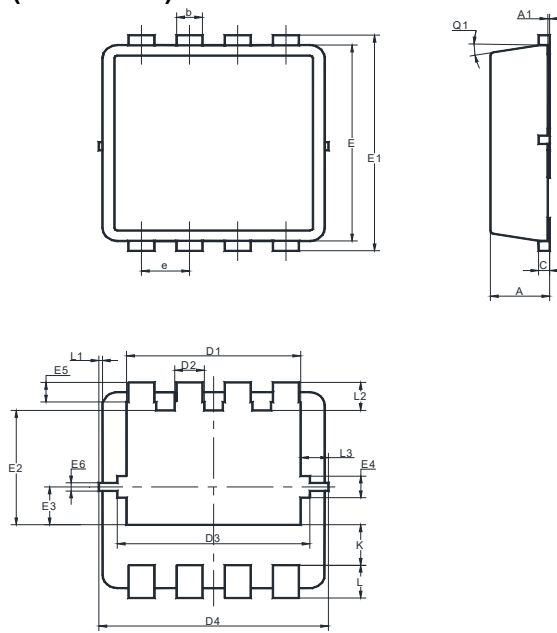

UNIT	A	A1	b	c	D1	D2	D3	D4	E	E1	E2	E3	E4
mm	0.9	0.05	0.35	0.25	2.6	0.5	2.7	3.2	3.1	3.3	1.85	0.68	0.43
	0.7	0	0.24	0.1	2.4	0.3	2.5	3	2.9	3.1	1.65	0.48	0.23

UNIT	E5	E6	e	K	L	L1	L2	L3	θ1
mm	0.4	0.25	0.7	0.72	0.5	0.1	0.53	0.475	12°
	0.2	0.15	0.6	0.52	0.3	0	0.33	0.275	0°

Recommended Soldering Footprint

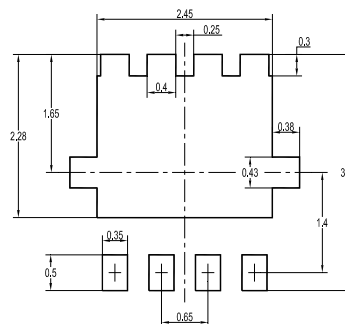

Packing information

Package	Tape Width (mm)	Pitch		Reel Size		Per Reel Packing Quantity
		mm	inch	mm	inch	
DFN3030	12	8 ± 0.1	0.315 ± 0.004	330	13	5,000

Marking information

" TM304N160LS " = Part No.

" ***** " = Date Code Marking

Font type: Arial

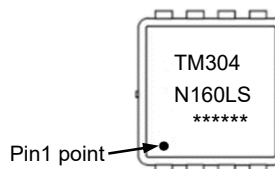

Disclaimer: Our company reserve the right to make modifications, enhancements, improvements, corrections or other changes to improve product design, functions and reliability, anytime without notice.

