

RB520S-40

Silicon Epitaxial Planar Schottky Barrier Diode

Features

- High reliability
- Extremely small surface mounting type

PINNING

PIN	DESCRIPTION
1	Cathode
2	Anode

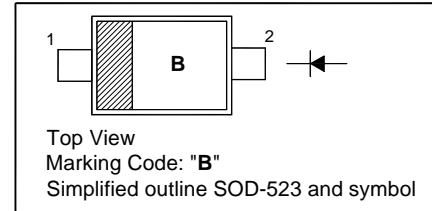

Absolute Maximum Ratings ($T_a = 25^\circ\text{C}$)

Parameter	Symbol	Value	Unit
Reverse Voltage	V_R	40	V
Mean Rectifying Current	$I_{F(AV)}$	200	mA
Peak Forward Surge Current	I_{FSM}	1	A
Junction Temperature	T_j	125	$^\circ\text{C}$
Storage Temperature Range	T_{stg}	- 40 to + 125	$^\circ\text{C}$

Characteristics at $T_a = 25^\circ\text{C}$

Parameter	Symbol	Max.	Unit
Forward Voltage at $I_F = 10\text{ mA}$ at $I_F = 100\text{ mA}$	V_F	0.39 0.55	V
Reverse Current at $V_R = 10\text{ V}$ at $V_R = 40\text{ V}$	I_R	1 10	μA

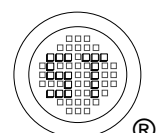

Electrical Characteristics Curves

Fig 1. Reverse Characteristics Curve

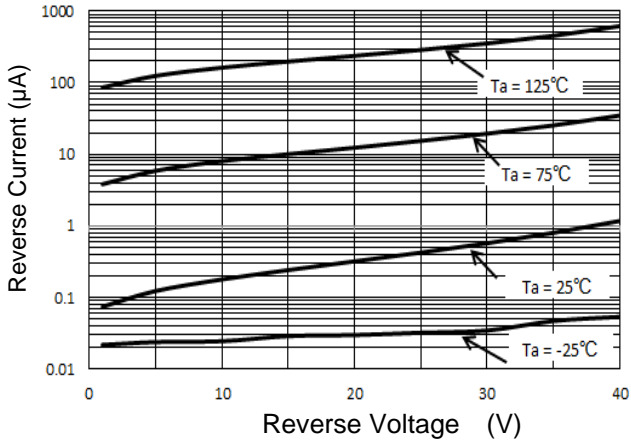

Fig 2. Forward Characteristics Curve

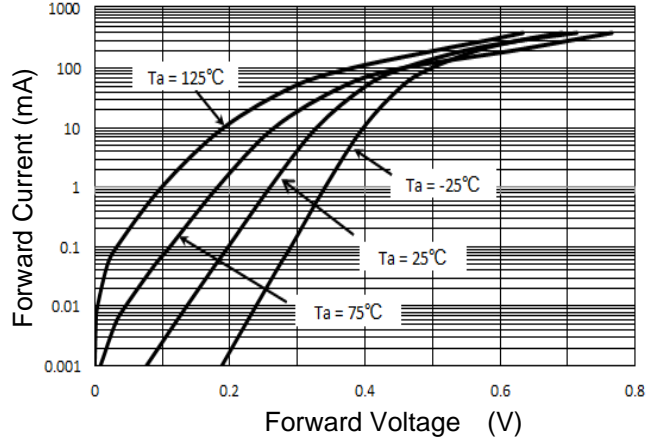
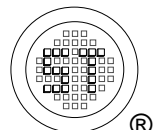
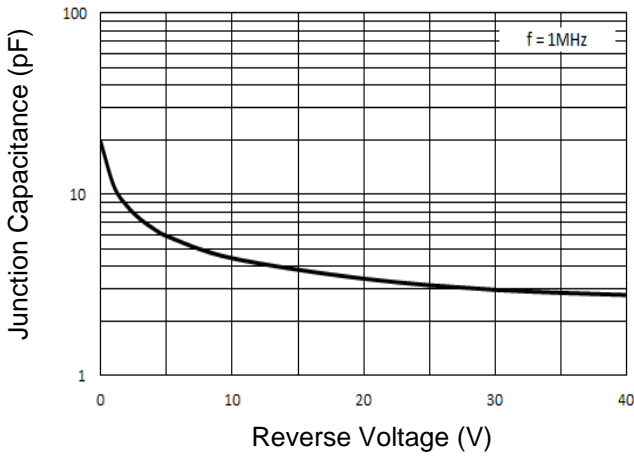

Fig 3. Junction Capacitance



RB520S-40

PACKAGE OUTLINE

Plastic surface mounted package; 2 leads

SOD-523

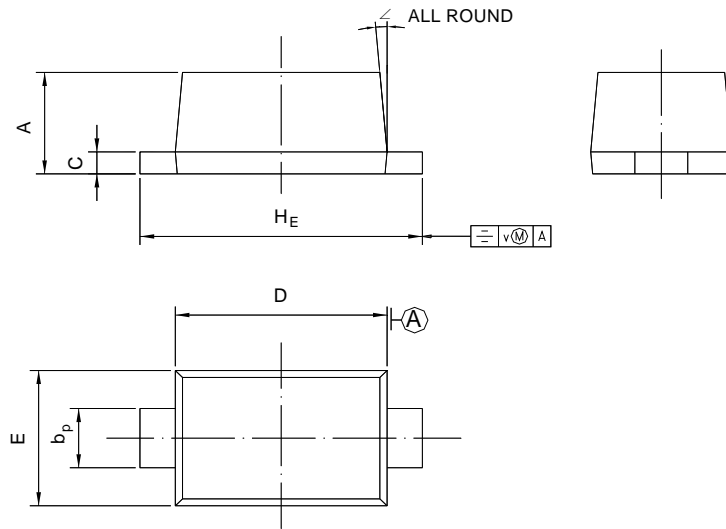

UNIT	A	b _p	C	D	E	H _E	V	∠
mm	0.70 0.60	0.4 0.3	0.135 0.100	1.25 1.15	0.85 0.75	1.7 1.5	0.1	5°

Recommended Soldering Footprint

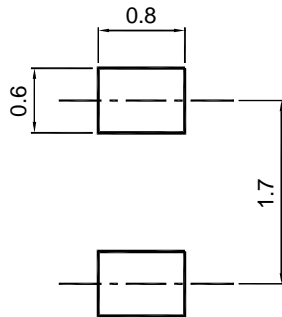

Packing information

Package	Tape Width (mm)	Pitch		Reel Size		Per Reel Packing Quantity
		mm	inch	mm	inch	
SOD-523	8	4 ± 0.1	0.157 ± 0.004	178	7	4,000

Marking information

" III " = Cathode line

" B " = Part No.

Font type: Arial

