

MMFTN2312-AH

N-Channel Enhancement Mode MOSFET

Features

- AEC-Q101 Qualified
- Surface-mounted package
- Halogen and Antimony Free(HAF), RoHS compliant

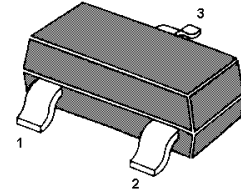
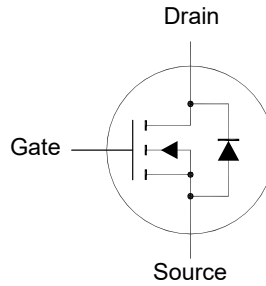

1. Gate 2. Source 3. Drain
SOT-23 Plastic Package

Applications

- Portable appliances
- Battery management

Absolute Maximum Ratings(at $T_a = 25^\circ\text{C}$ unless otherwise specified)

Parameter	Symbol	Value	Unit
Drain-Source Voltage	V_{DSS}	20	V
Drain-Gate Voltage	V_{GS}	± 8	V
Drain Current - Continuous	I_D	4.5	A
Drain Current - Pulsed ¹⁾	I_{DM}	13.5	A
Total Power Dissipation ²⁾	P_{tot}	1.25	W
Operating Junction and Storage Temperature Range	T_j, T_{stg}	- 55 to + 150	$^\circ\text{C}$

Thermal Characteristics

Parameter	Symbol	Value	Unit
Thermal Resistance from Junction to Ambient ²⁾	$R_{\theta JA}$	100	$^\circ\text{C/W}$

¹⁾ Pulse Test: Pulse Width $\leq 100 \mu\text{s}$, Duty Cycle $\leq 2\%$, Repetitive rating, pulse width limited by junction temperature $T_{J(MAX)}=150^\circ\text{C}$.

²⁾ Device mounted on FR-4 substrate PC board, 2oz copper, with 1-inch square copper plate in still air, $t \leq 10 \text{ s}$.

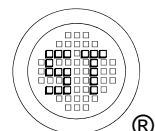

MMFTN2312-AH

Characteristics at $T_a = 25^\circ\text{C}$ unless otherwise specified

Parameter	Symbol	Min.	Typ.	Max.	Unit
STATIC PARAMETERS					
Drain-Source Breakdown Voltage at $I_D = 250 \mu\text{A}$	$V_{(BR)DSS}$	20	-	-	V
Drain-Source Leakage Current at $V_{DS} = 20 \text{ V}$	I_{DSS}	-	-	1	μA
Gate-Source Leakage Current at $V_{GS} = \pm 8 \text{ V}$	I_{GSS}	-	-	± 100	nA
Gate-Source Threshold Voltage at $V_{GS} = V_{DS}, I_D = 250 \mu\text{A}$	$V_{GS(th)}$	0.5	-	1.2	V
Drain-Source On-State Resistance at $V_{GS} = 4.5 \text{ V}, I_D = 5 \text{ A}$ at $V_{GS} = 2.5 \text{ V}, I_D = 4.5 \text{ A}$	$R_{DS(on)}$	-	-	33 40	m Ω
DYNAMIC PARAMETERS					
Forward Transconductance at $V_{DS} = 10 \text{ V}, I_D = 5 \text{ A}$	g_{fs}	-	9	-	S
Gate Resistance at $V_{GS} = 0 \text{ V}, V_{DS} = 0 \text{ V}, f = 1 \text{ MHz}$	R_g	-	2.9	-	Ω
Input Capacitance at $V_{GS} = 0 \text{ V}, V_{DS} = 10 \text{ V}, f = 1 \text{ MHz}$	C_{iss}	-	871	-	pF
Output Capacitance at $V_{GS} = 0 \text{ V}, V_{DS} = 10 \text{ V}, f = 1 \text{ MHz}$	C_{oss}	-	117	-	pF
Reverse Transfer Capacitance at $V_{GS} = 0 \text{ V}, V_{DS} = 10 \text{ V}, f = 1 \text{ MHz}$	C_{rss}	-	87	-	pF
Gate charge total at $V_{DS} = 10 \text{ V}, V_{GS} = 4.5 \text{ V}, I_D = 5 \text{ A}$ at $V_{DS} = 10 \text{ V}, V_{GS} = 2.5 \text{ V}, I_D = 5 \text{ A}$	Q_g	-	9.6 5.8	-	nC
Gate to Source Charge at $V_{DS} = 10 \text{ V}, V_{GS} = 4.5 \text{ V}, I_D = 5 \text{ A}$	Q_{gs}	-	2.2	-	nC
Gate to Drain Charge at $V_{DS} = 10 \text{ V}, V_{GS} = 4.5 \text{ V}, I_D = 5 \text{ A}$	Q_{gd}	-	2.3	-	nC
Turn-On Delay Time at $V_{DS} = 10 \text{ V}, V_{GS} = 10 \text{ V}, I_D = 5 \text{ A}, R_g = 3.3 \Omega$	$t_{d(on)}$	-	9	-	ns
Turn-On Rise Time at $V_{DS} = 10 \text{ V}, V_{GS} = 10 \text{ V}, I_D = 5 \text{ A}, R_g = 3.3 \Omega$	t_r	-	18	-	ns
Turn-Off Delay Time at $V_{DS} = 10 \text{ V}, V_{GS} = 10 \text{ V}, I_D = 5 \text{ A}, R_g = 3.3 \Omega$	$t_{d(off)}$	-	15	-	ns
Turn-Off Fall Time at $V_{DS} = 10 \text{ V}, V_{GS} = 10 \text{ V}, I_D = 5 \text{ A}, R_g = 3.3 \Omega$	t_f	-	2	-	ns
Body-Diode PARAMETERS					
Diode Forward Voltage at $I_s = 5 \text{ A}$	V_{SD}	-	-	1.2	V
Body-Diode Continuous Current	I_s	-	-	4.5	A
Body Diode Reverse Recovery Time at $I_s = 5 \text{ A}, di/dt = 100 \text{ A} / \mu\text{s}$	t_{rr}	-	10	-	ns
Body Diode Reverse Recovery Charge at $I_s = 5 \text{ A}, di/dt = 100 \text{ A} / \mu\text{s}$	Q_{rr}	-	1.6	-	nC

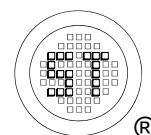

Electrical Characteristics Curves

Fig. 1 Typical Output Characteristics

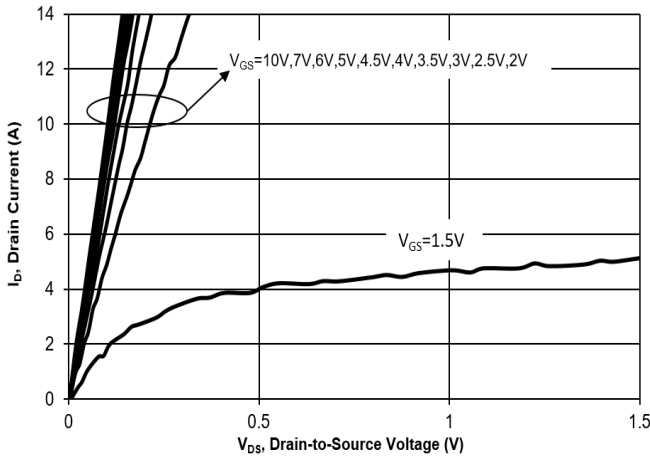

Fig. 2 Typical Transfer Characteristics

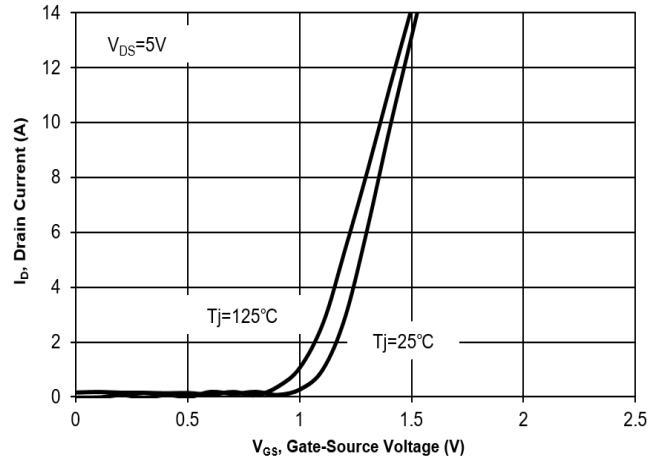

Fig. 3 On-Resistance vs. Drain Current

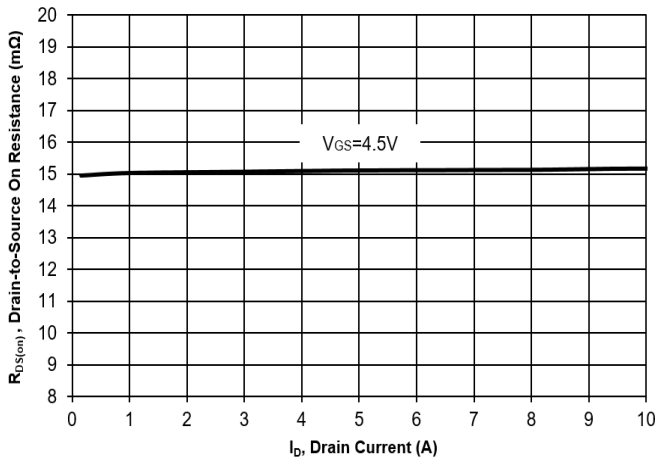

Fig. 4 On-Resistance vs. Gate to Source Voltage

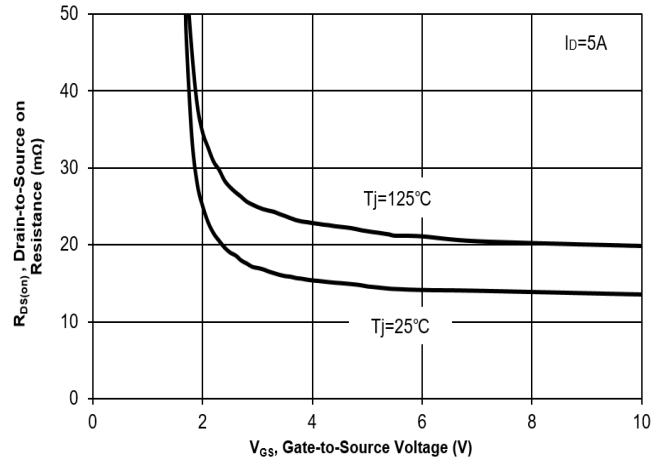

Fig. 5 On-Resistance vs. T_J

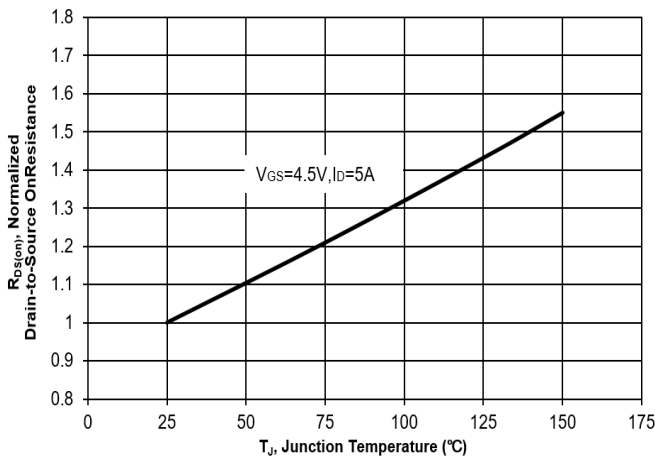
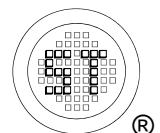
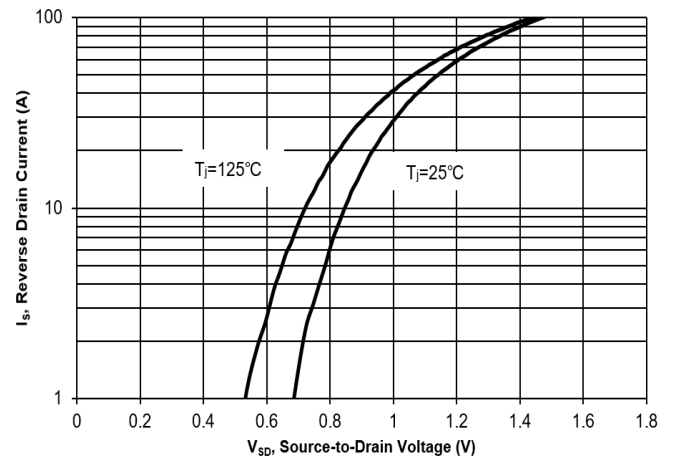

Fig. 6 Typical Body-Diode Forward Characteristics



Electrical Characteristics Curves

Fig. 7 Typical Junction Capacitance

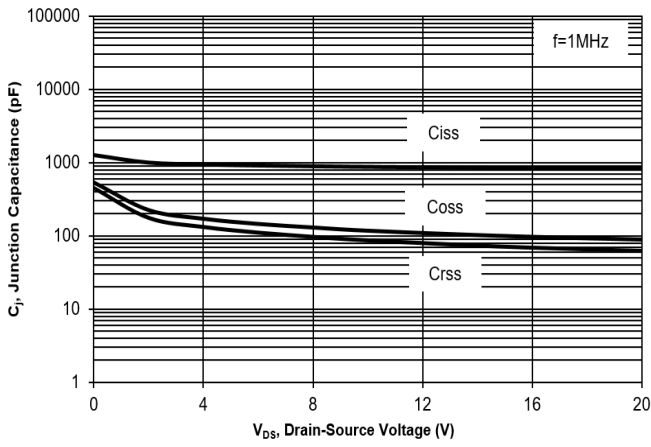

Fig. 8 Drain-Source Leakage Current vs. T_j

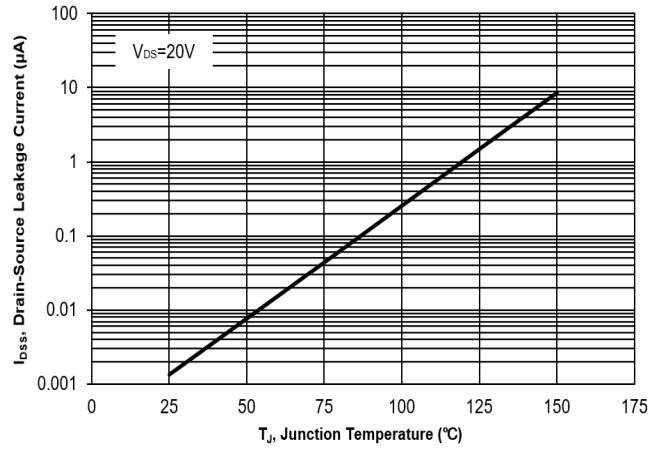

Fig. 9 $V_{(BR)DSS}$ vs. Junction Temperature

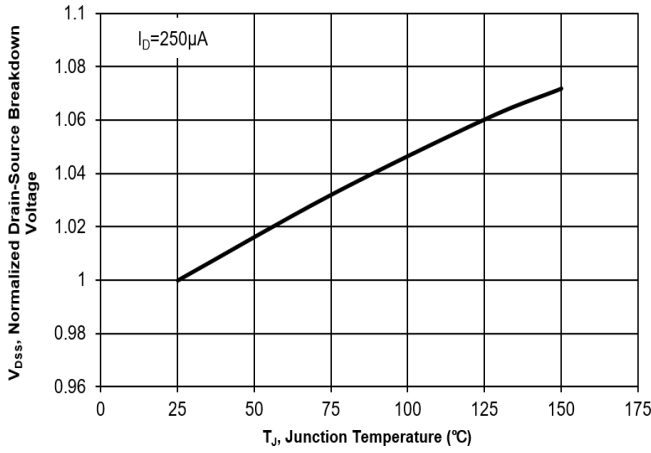

Fig. 10 Gate Threshold Variation vs. T_j

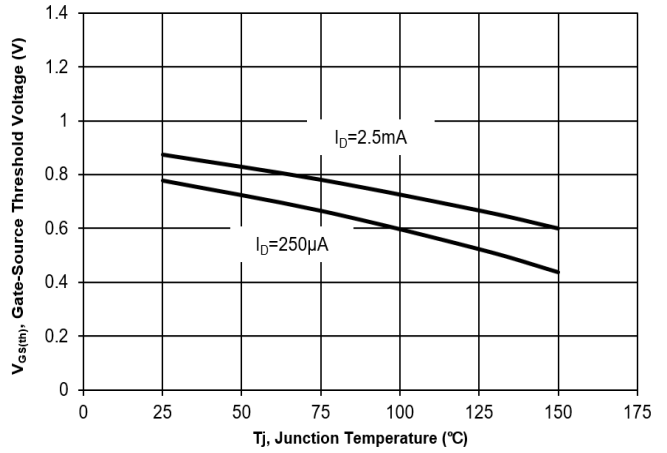
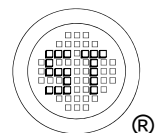
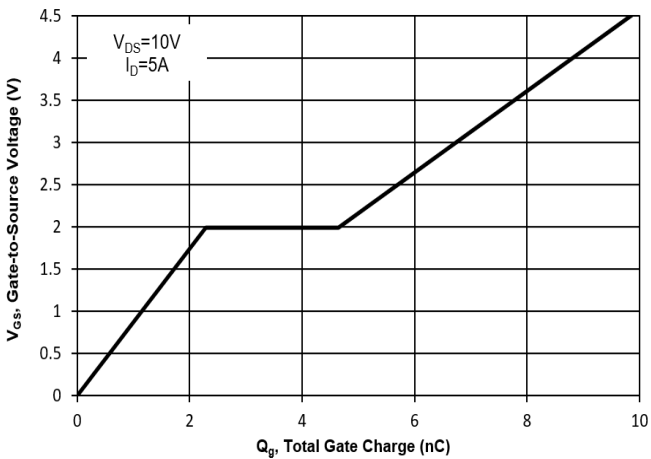

Fig. 11 Gate Charge



Test Circuits

Fig.1-1 Switching times test circuit

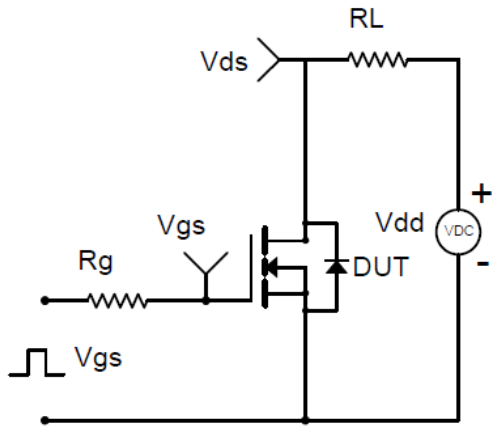

Fig.1-2 Switching Waveform

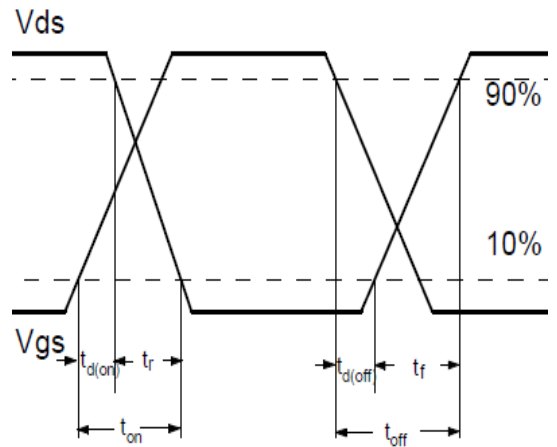

Fig.2-1 Gate charge test circuit

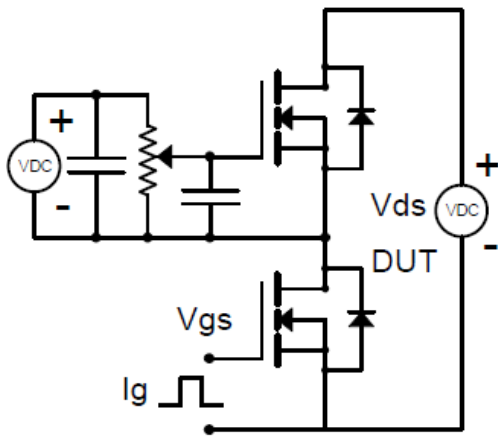
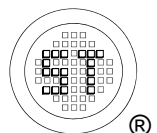
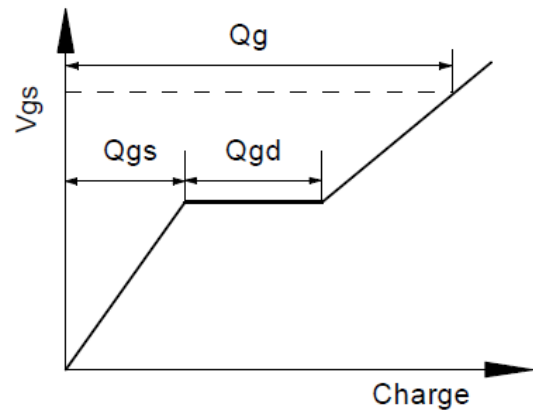

Fig.2-2 Gate charge waveform



MMFTN2312-AH

Package Outline (Dimensions in mm)

SOT-23

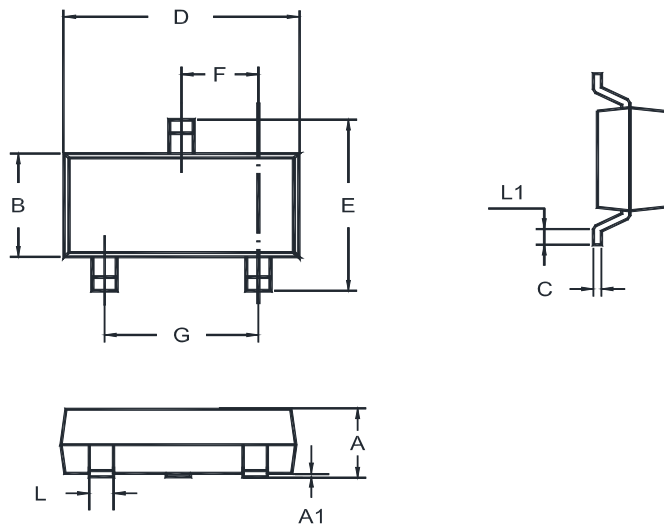

Unit	A	A1	B	C	D	E	F	G	L	L1
mm	1.20	0.100	1.40	0.19	3.04	2.6	1.02	2.04	0.51	0.2
	0.89	0.013	1.20	0.08	2.80	2.2	0.89	1.78	0.37	MIN

Recommended Soldering Footprint

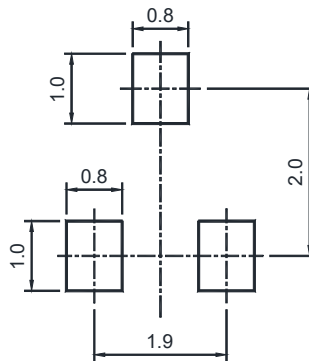

Packing information

Package	Tape Width (mm)	Pitch		Reel Size		Per Reel Packing Quantity
		mm	inch	mm	inch	
SOT-23	8	4 ± 0.1	0.157 ± 0.004	178	7	3,000

Marking information

" M23 " = Part No.

" • " = HAF (Halogen and Antimony Free)

" YM " = Date Code Marking

" Y " = Year

" M " = Month

Font type: Arial

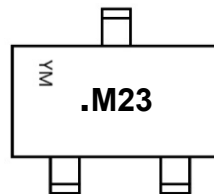

Disclaimer: Our company reserve the right to make modifications, enhancements, improvements, corrections or other changes to improve product design, functions and reliability, anytime without notice. Semtech Electronics Limited makes no warranties, representations or warranties regarding the suitability of its products for any particular purpose, and does not accept any liability arising from the application or use of any product or circuit such as: Apply to medical, military, aircraft, space or life support equipment and expressly waive any and all liability, including but not limited to special, consequential or collateral damage.

