

MMDT1901DW...MMDT1909DW

Dual NPN Silicon Epitaxial Planar Digital Transistor

For switching and interface circuit and drive circuit applications

Features

- Transistors with built-in bias resistors R1 and R2
- Simplification of circuit design
- Reduces number of components and board space

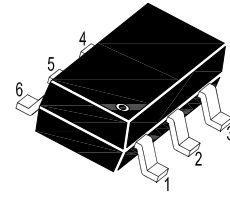
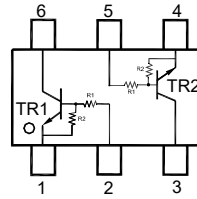

TR1: 1. Emitter 2. Base 6. Collector
TR2: 4. Emitter 5. Base 3. Collector
SOT-363 Plastic Package

Resistor Values

Type	R1 (KΩ)	R2 (KΩ)	Type	R1 (KΩ)	R2 (KΩ)
MMDT1901DW	4.7	4.7	MMDT1906DW	4.7	47
MMDT1902DW	10	10	MMDT1907DW	10	47
MMDT1903DW	22	22	MMDT1908DW	22	47
MMDT1904DW	47	47	MMDT1909DW	47	22
MMDT1905DW	2.2	47			

Absolute Maximum Ratings at $T_a = 25^\circ\text{C}$

Parameter	Symbol	Value	Unit
Collector Base Voltage	V_{CBO}	50	V
Collector Emitter Voltage	V_{CEO}	50	V
Input Voltage	V_{IN}	MMDT1901DW: 20, - 10 MMDT1902DW: 30, - 10 MMDT1903DW: 40, - 10 MMDT1904DW: 40, - 10 MMDT1905DW: 12, - 5 MMDT1906DW: 20, - 5 MMDT1907DW: 30, - 6 MMDT1908DW: 40, - 7 MMDT1909DW: 40, - 15	V
Collector Current	I_C	100	mA
Total Power Dissipation ¹⁾	P_{tot}	200	mW
Junction Temperature	T_j	150	$^\circ\text{C}$
Storage Temperature Range	T_{stg}	- 55 to + 150	$^\circ\text{C}$

Thermal Characteristics

Parameter	Symbol	Max.	Unit
Thermal Resistance from Junction to Ambient ¹⁾	$R_{\theta JA}$	625	$^\circ\text{C/W}$

¹⁾ Device mounted on FR-4 substrate PC board, with minimum recommended pad layout.

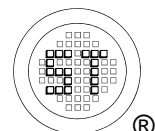

MMDT1901DW...MMDT1909DW

Characteristics at $T_a = 25^\circ\text{C}$

Parameter	Symbol	Min.	Typ.	Max.	Unit	
DC Current Gain at $V_{CE} = 5\text{ V}$, $I_C = 10\text{ mA}$	MMDT1901DW MMDT1902DW MMDT1903DW MMDT1904DW MMDT1905DW MMDT1906DW MMDT1907DW MMDT1908DW MMDT1909DW	h_{FE} h_{FE} h_{FE} h_{FE} h_{FE} h_{FE} h_{FE} h_{FE} h_{FE}	30 50 70 80 80 80 80 80 80	- - - - - - - - -	- - - - - - - - -	- - - - - - - - -
Collector Base Cutoff Current at $V_{CB} = 50\text{ V}$		I_{CBO}	-	-	100	nA
Collector Emitter Cutoff Current at $V_{CE} = 50\text{ V}$		I_{CEO}	-	-	0.5	μA
Emitter Base Cutoff Current at $V_{EB} = 10\text{ V}$ at $V_{EB} = 10\text{ V}$ at $V_{EB} = 10\text{ V}$ at $V_{EB} = 10\text{ V}$ at $V_{EB} = 5\text{ V}$ at $V_{EB} = 5\text{ V}$ at $V_{EB} = 6\text{ V}$ at $V_{EB} = 7\text{ V}$ at $V_{EB} = 15\text{ V}$	MMDT1901DW MMDT1902DW MMDT1903DW MMDT1904DW MMDT1905DW MMDT1906DW MMDT1907DW MMDT1908DW MMDT1909DW	I_{EBO}	820 380 170 82 78 74 81 78 167	- - - - - - - - -	1520 710 330 150 145 138 150 145 311	μA
Collector Base Breakdown Voltage at $I_C = 10\text{ }\mu\text{A}$		$V_{(BR)CBO}$	50	-	-	V
Collector Emitter Breakdown Voltage at $I_C = 1\text{ mA}$		$V_{(BR)CEO}$	50	-	-	V
Collector Emitter Saturation Voltage at $I_C = 5\text{ mA}$, $I_B = 0.25\text{ mA}$		$V_{CE(sat)}$	-	-	0.3	V
Input Voltage (ON) at $V_{CE} = 0.2\text{ V}$, $I_C = 5\text{ mA}$	MMDT1901DW MMDT1902DW MMDT1903DW MMDT1904DW MMDT1905DW MMDT1906DW MMDT1907DW MMDT1908DW MMDT1909DW	$V_{I(ON)}$	1.1 1.2 1.3 1.5 0.6 0.7 0.7 1 2.2	- - - - - - - - -	2 2.4 3 5 1.1 1.3 1.8 2.6 5.8	V
Input Voltage (OFF) at $V_{CE} = 5\text{ V}$, $I_C = 100\text{ }\mu\text{A}$	MMDT1901DW~1904DW MMDT1905DW~1906DW MMDT1907DW MMDT1908DW MMDT1909DW	$V_{I(OFF)}$	1 0.5 0.5 0.6 1.5	- - - - -	1.5 0.8 1 1.16 2.6	V
Transition Frequency at $V_{CE} = 10\text{ V}$, $I_C = 5\text{ mA}$		f_T	-	250	-	MHz

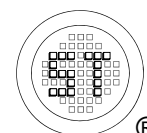

MMDT1901DW...MMDT1909DW

Characteristics at $T_a = 25^\circ\text{C}$

Input Resistance	MMDT1901DW	R ₁	3.29	4.7	6.11	KΩ
	MMDT1902DW		7	10	13	
	MMDT1903DW		15.4	22	28.6	
	MMDT1904DW		32.9	47	61.1	
	MMDT1905DW		1.54	2.2	2.86	
	MMDT1906DW		3.29	4.7	6.11	
	MMDT1907DW		7	10	13	
	MMDT1908DW		15.4	22	28.6	
	MMDT1909DW		32.9	47	61.1	
Resistance Ratio	MMDT1901DW~1904DW	R ₁ /R ₂	0.9	1	1.1	-
	MMDT1905DW		0.0421	0.0468	0.0515	
	MMDT1906DW		0.09	0.1	0.11	
	MMDT1907DW		0.191	0.213	0.232	
	MMDT1908DW		0.421	0.468	0.515	
	MMDT1909DW		1.92	2.14	2.35	

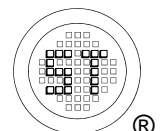

MMDT1901DW...MMDT1909DW

Electrical Characteristics Curves (MMDT1901DW)

Fig 1. Collector Current vs. $V_{I(ON)}$

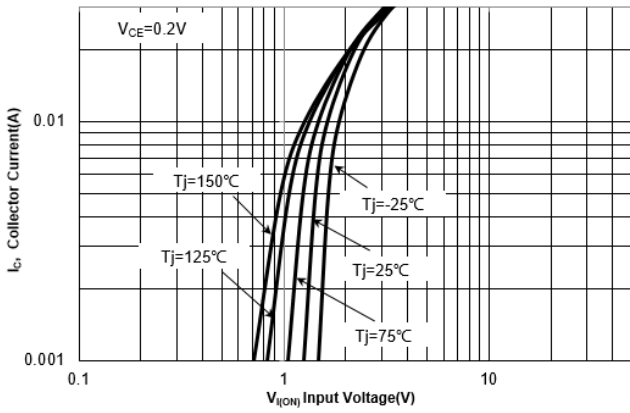

Fig 2. Collector Current vs. $V_{I(off)}$

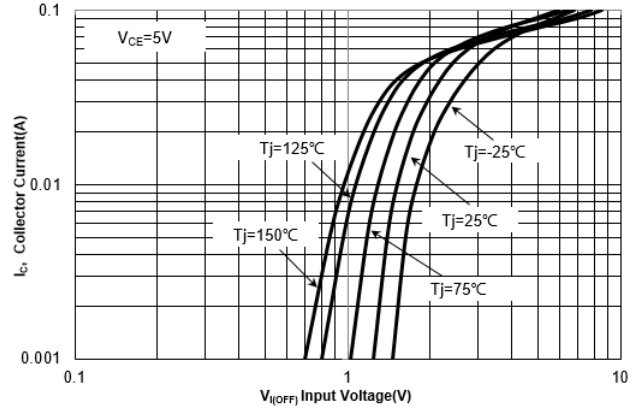

Fig 3. DC Current Gain vs. Collector Current

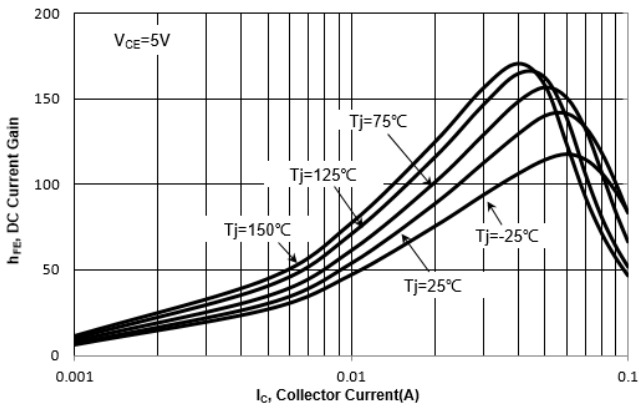
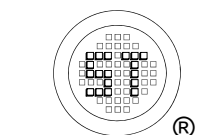
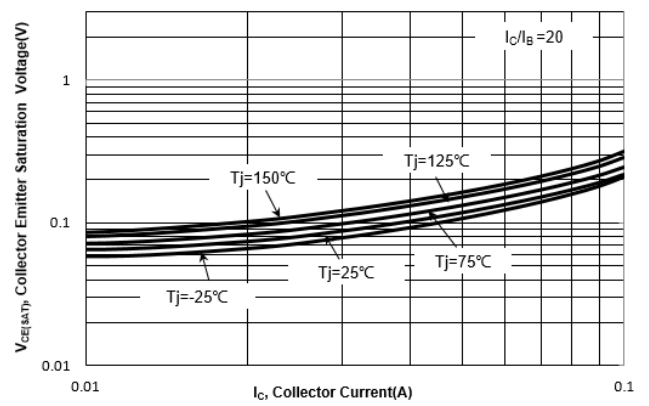

Fig 4. $V_{CE(sat)}$ vs. Collector Current



MMDT1901DW...MMDT1909DW

Electrical Characteristics Curves (MMDT1902DW)

Fig 1. Collector Current vs. $V_{I(ON)}$

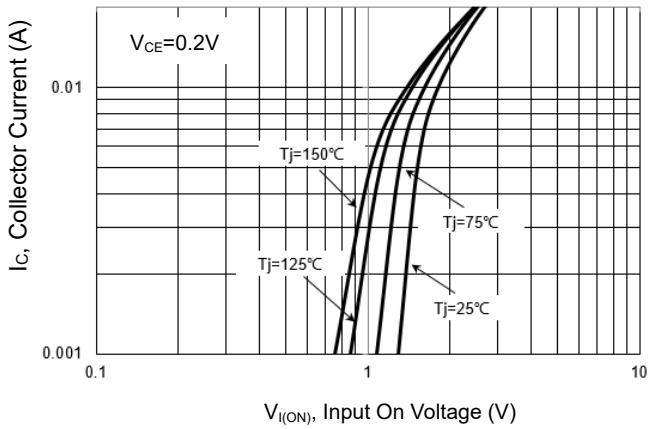

Fig 2. Collector Current vs. $V_{I(off)}$

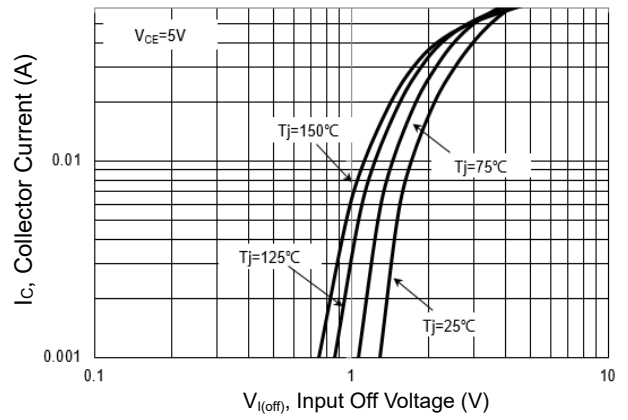

Fig 3. DC Current Gain vs. Collector Current

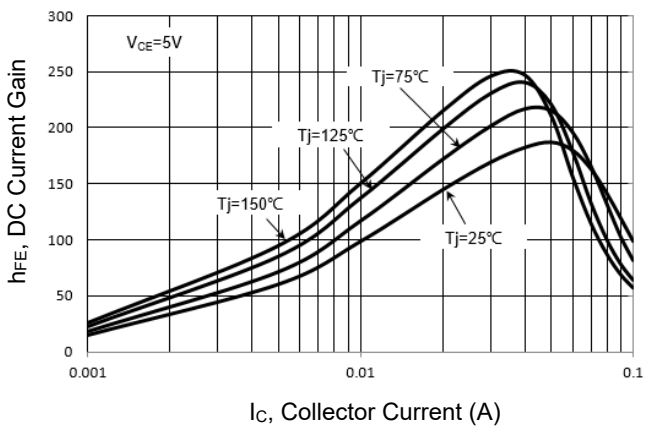
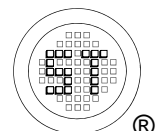
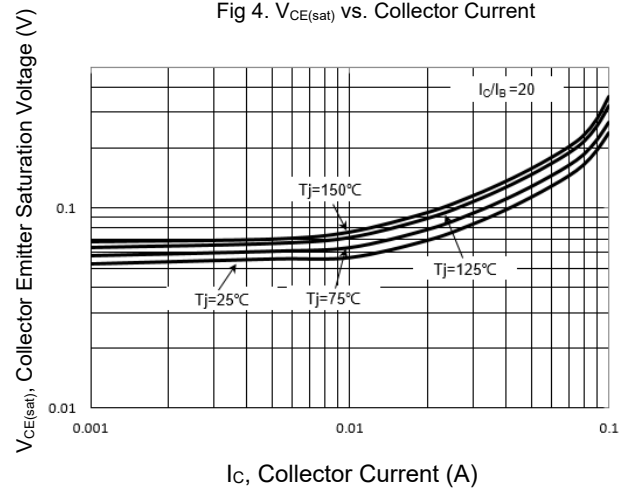

Fig 4. $V_{CE(sat)}$ vs. Collector Current



MMDT1901DW...MMDT1909DW

Electrical Characteristics Curves (MMDT1903DW)

Fig 1. Collector Current vs. $V_{I(ON)}$

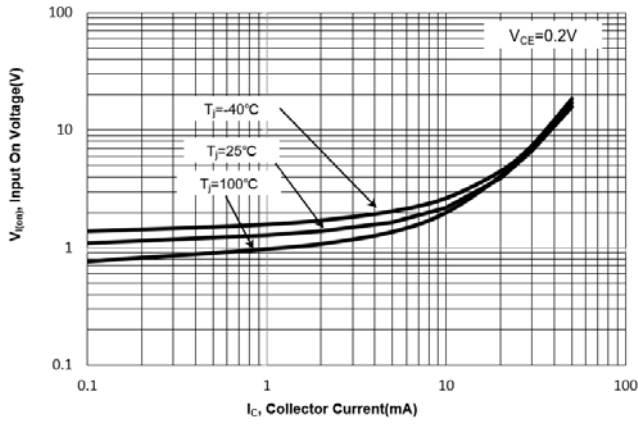

Fig 2. Collector Current vs. $V_{I(off)}$

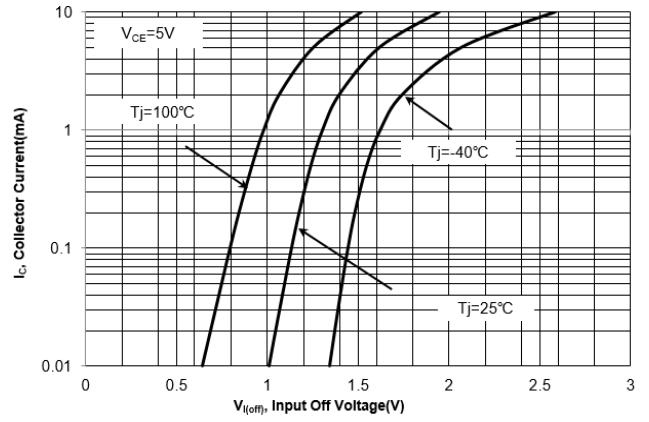

Fig 3. DC Current Gain vs. Collector Current

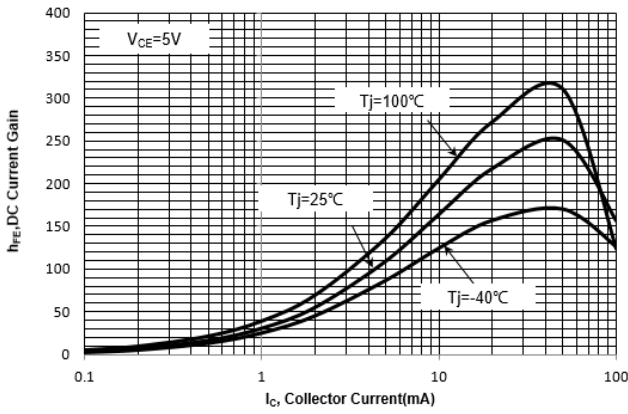
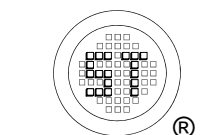
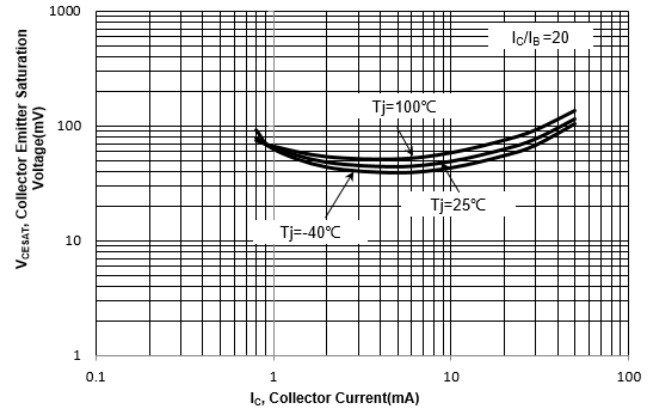

Fig 4. $V_{CE(sat)}$ vs. Collector Current



MMDT1901DW...MMDT1909DW

Electrical Characteristics Curves (MMDT1904DW)

Fig 1. Collector Current vs. $V_{I(ON)}$

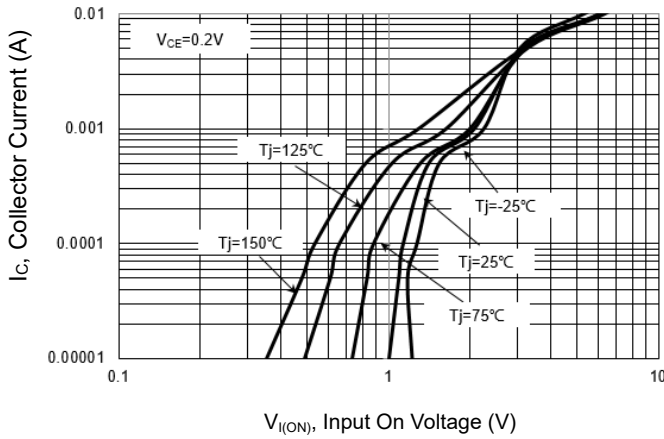

Fig 2. Collector Current vs. $V_{I(off)}$

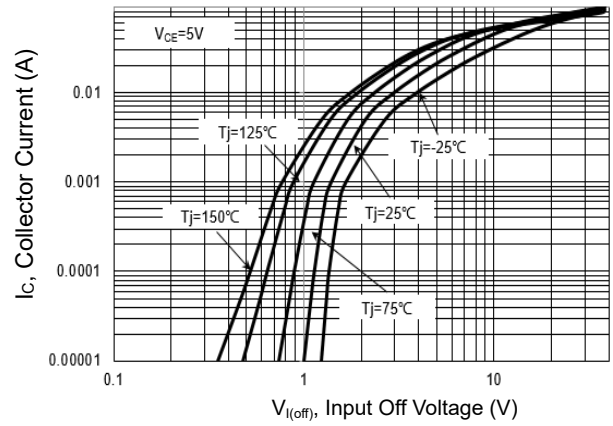

Fig 3. DC Current Gain vs. Collector Current

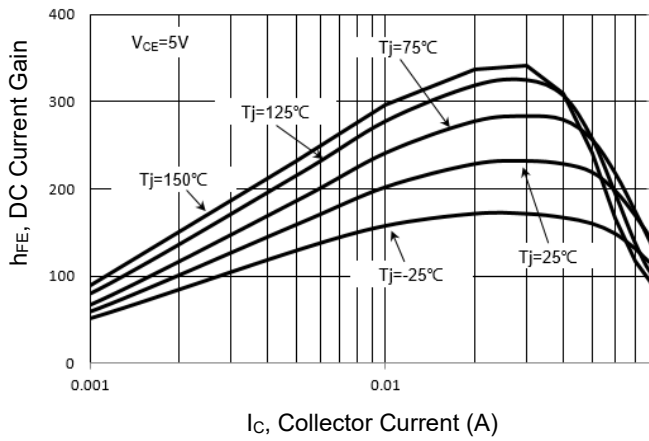
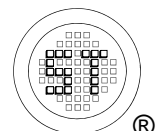
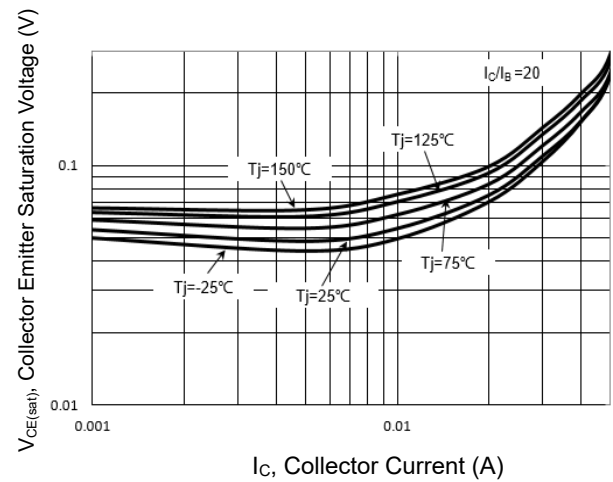

Fig 4. $V_{CE(sat)}$ vs. Collector Current



MMDT1901DW...MMDT1909DW

Electrical Characteristics Curves (MMDT1905DW)

Fig 1. Collector Current vs. $V_{I(ON)}$

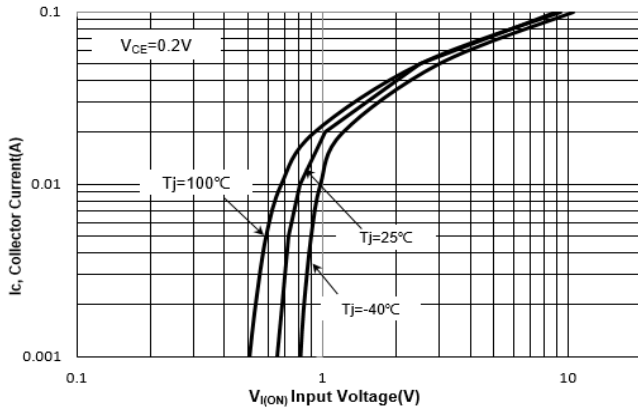

Fig 2. Collector Current vs. $V_{I(off)}$

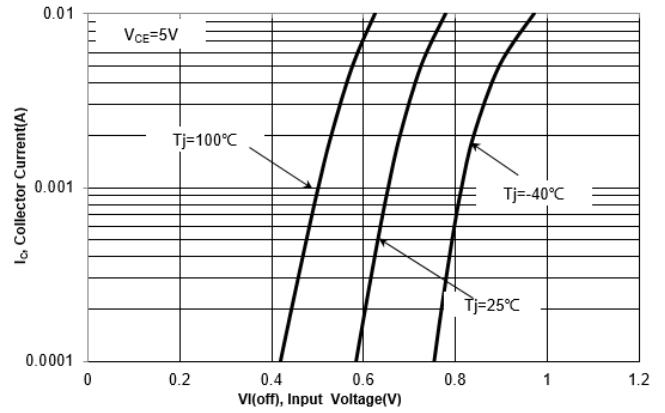

Fig 3. DC Current Gain vs. Collector Current

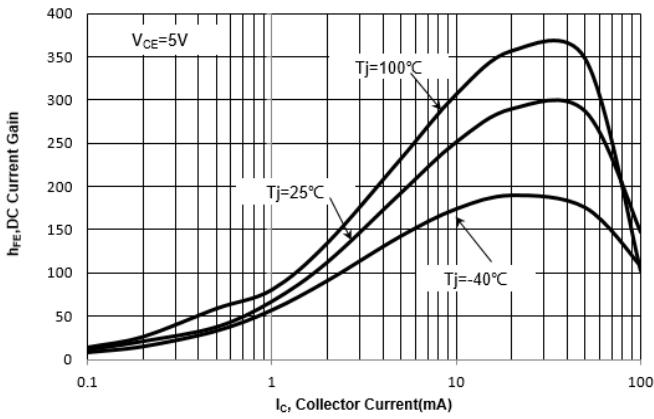
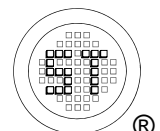
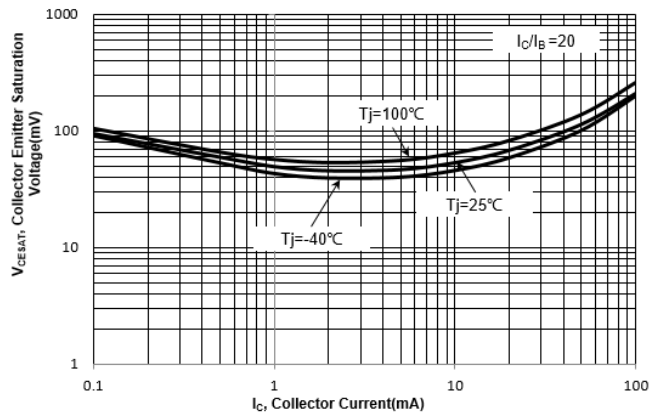

Fig 4. $V_{CE(sat)}$ vs. Collector Current



MMDT1901DW...MMDT1909DW

Electrical Characteristics Curves (MMDT1906DW)

Fig 1. Collector Current vs. $V_{I(ON)}$

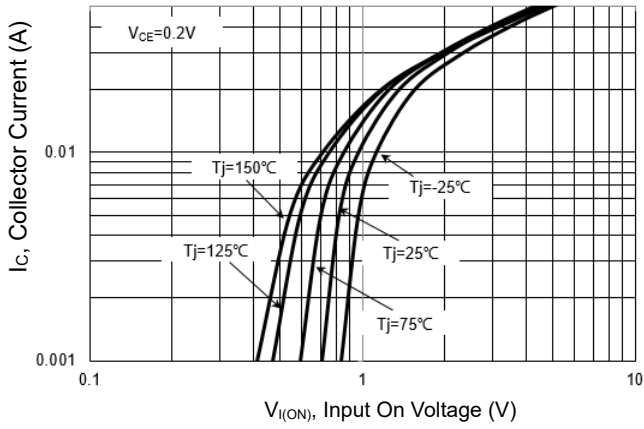

Fig 2. Collector Current vs. $V_{I(off)}$

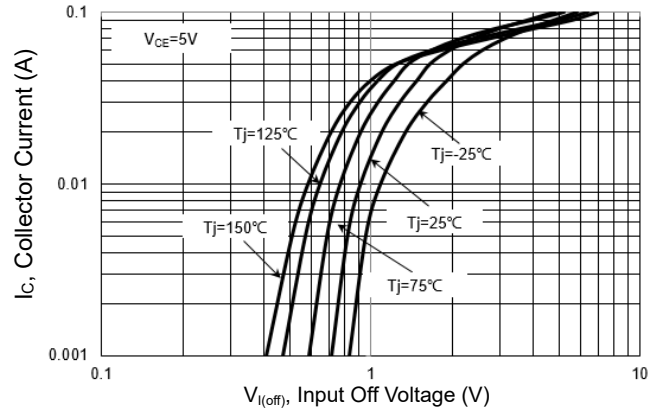

Fig 3. DC Current Gain vs. Collector Current

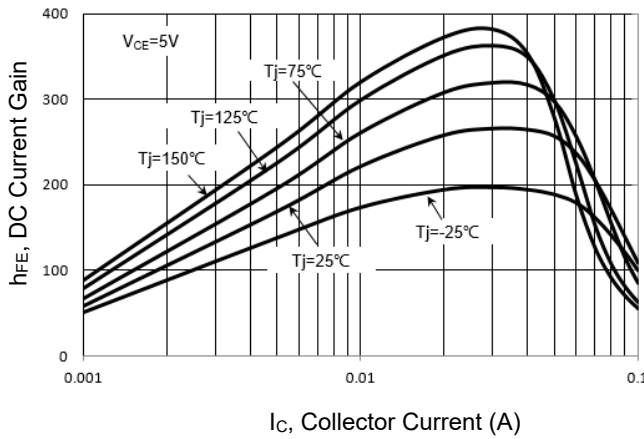
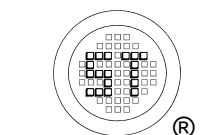
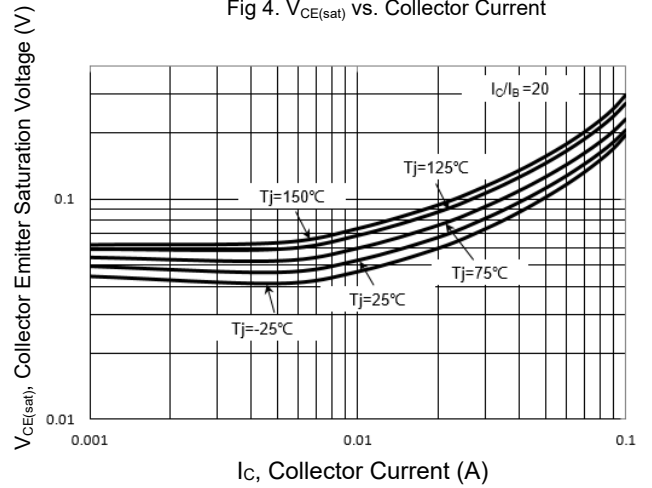

Fig 4. $V_{CE(sat)}$ vs. Collector Current



MMDT1901DW...MMDT1909DW

Electrical Characteristics Curves (MMDT1907DW)

Fig 1. Collector Current vs. $V_{I(ON)}$

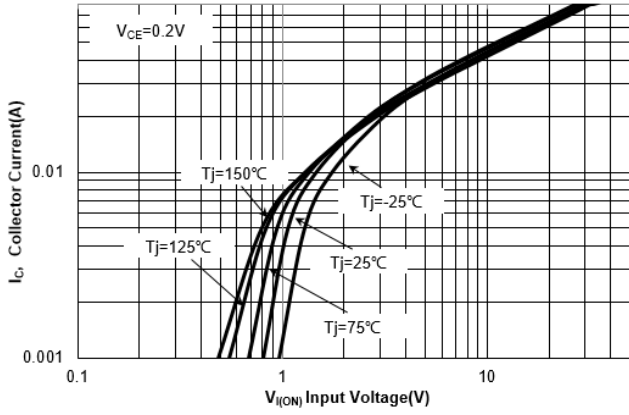

Fig 2. Collector Current vs. $V_{I(off)}$

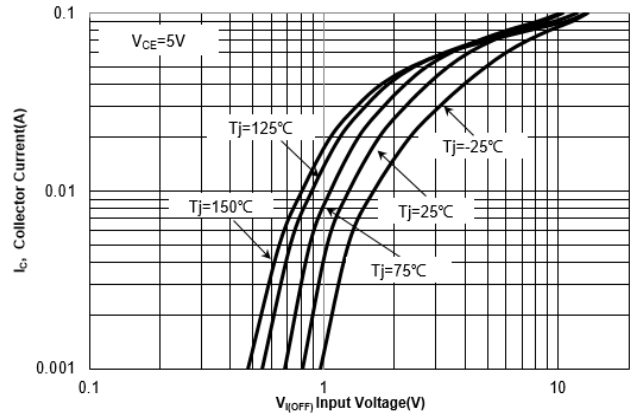

Fig 3. DC Current Gain vs. Collector Current

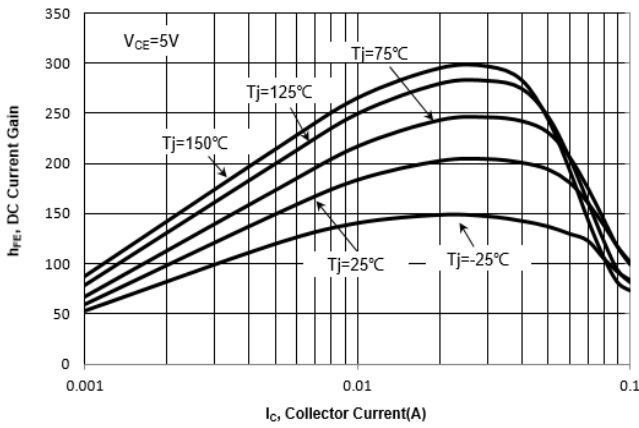
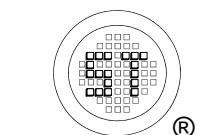
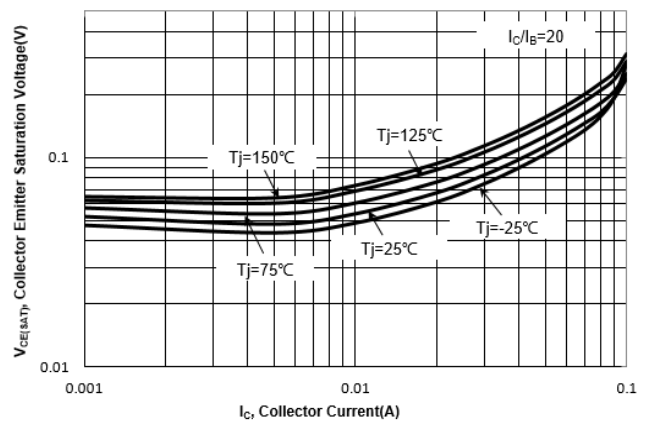

Fig 4. $V_{CE(sat)}$ vs. Collector Current



MMDT1901DW...MMDT1909DW

Electrical Characteristics Curves (MMDT1908DW)

Fig 1. Collector Current vs. $V_{I(ON)}$

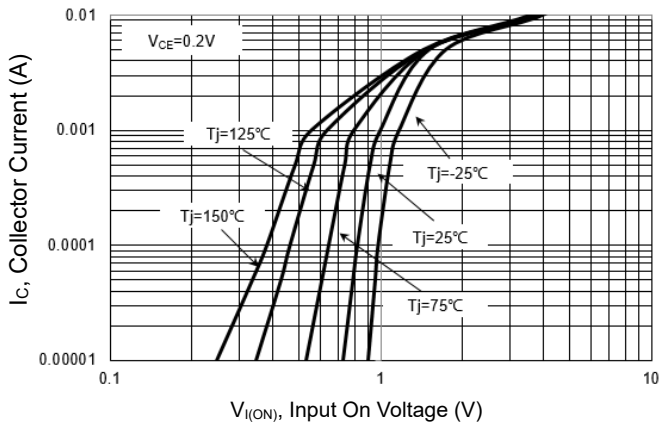

Fig 2. Collector Current vs. $V_{I(off)}$

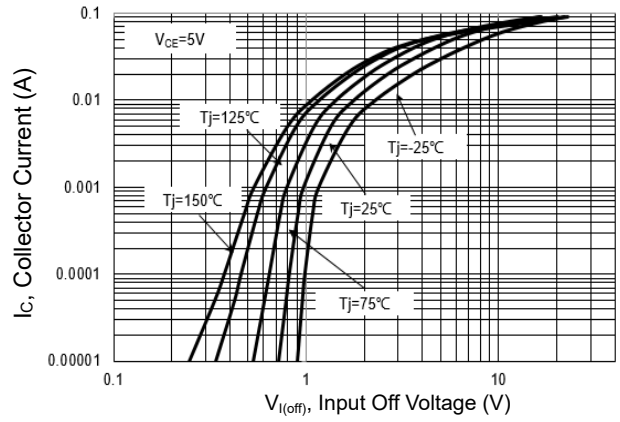

Fig 3. DC Current Gain vs. Collector Current

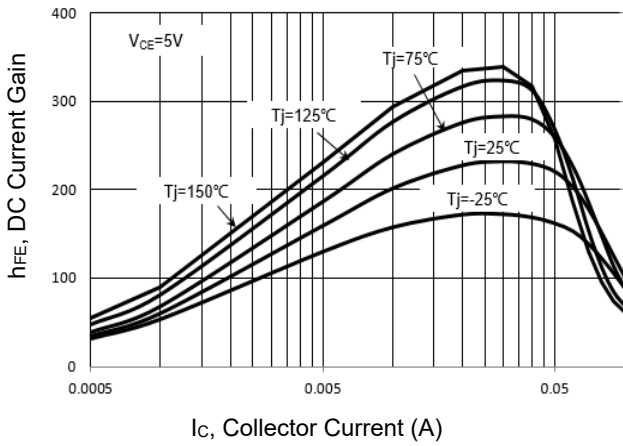
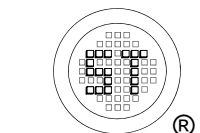
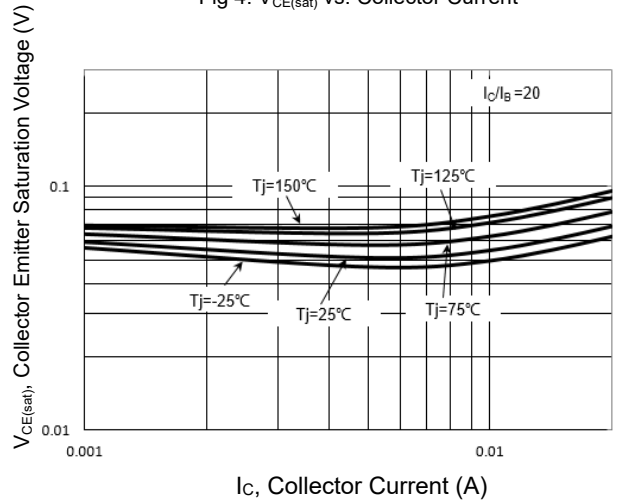

Fig 4. $V_{CE(sat)}$ vs. Collector Current



MMDT1901DW...MMDT1909DW

Electrical Characteristics Curves (MMDT1909DW)

Fig 1. Collector Current vs. $V_{I(ON)}$

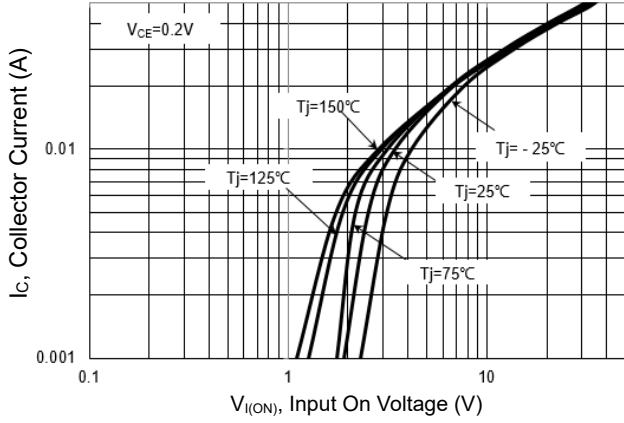

Fig 2. Collector Current vs. $V_{I(off)}$

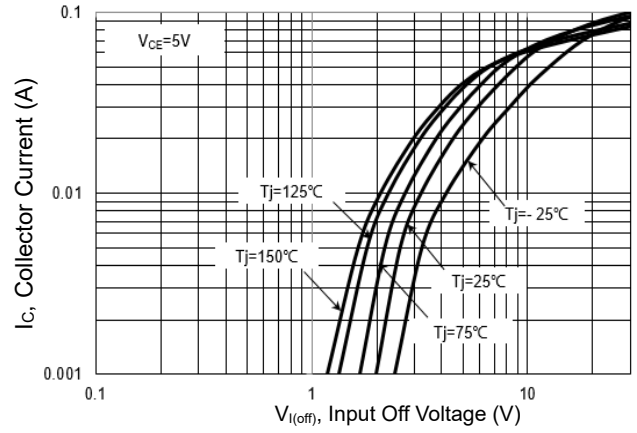

Fig 3. DC Current Gain vs. Collector Current

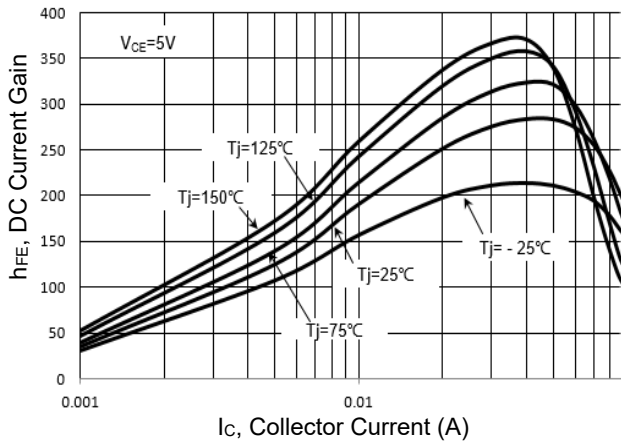
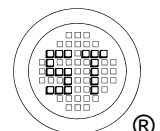
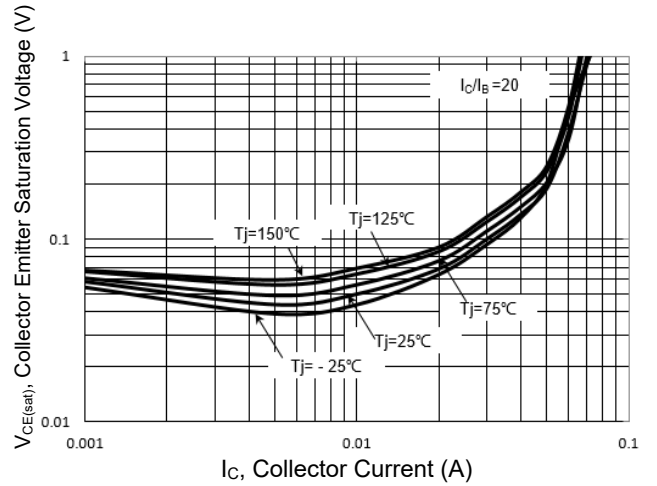

Fig 4. $V_{CE(sat)}$ vs. Collector Current



MMDT1901DW...MMDT1909DW

Package Outline (Dimensions in mm)

SOT-363

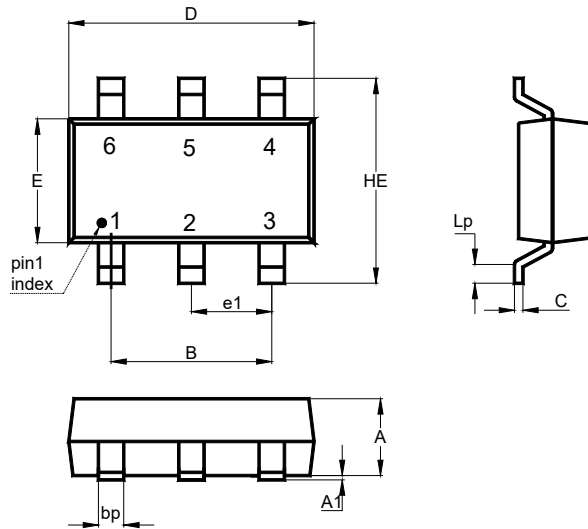

Unit	A	A1	B	C	D	E	e1	HE	Lp	bp
mm	1.0	0.1	1.3	0.25	2.2	1.35	0.65	2.2	0.4	0.3
	0.9	0	typ.	0.1	1.8	1.15	typ.	2.0	0.15	0.1

Recommended Soldering Footprint

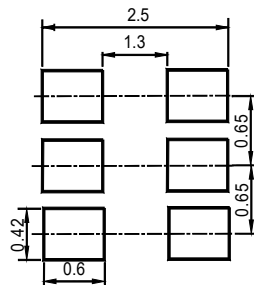

Packing information

Package	Tape Width (mm)	Pitch		Reel Size		Per Reel Packing Quantity
		mm	inch	mm	inch	
SOT-363	8	4 ± 0.1	0.157 ± 0.004	178	7	3,000

Marking information

"**" = Part No.

Type	Marking	Type	Marking	Type	Marking
MMDT1901DW	XA	MMDT1904DW	XD	MMDT1907DW	XG
MMDT1902DW	XB	MMDT1905DW	XE	MMDT1908DW	XH
MMDT1903DW	XC	MMDT1906DW	XF	MMDT1909DW	XJ

"YM" = Date Code Marking

"Y" = Year

"M" = Month

Font type: Arial

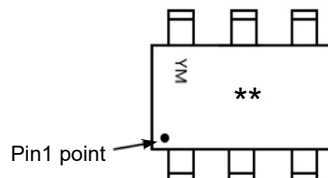

Disclaimer: Our company reserve the right to make modifications, enhancements, improvements, corrections or other changes to improve product design, functions and reliability, anytime without notice. Semtech Electronics Limited makes no warranties, representations or warranties regarding the suitability of its products for any particular purpose, and does not accept any liability arising from the application or use of any product or circuit such as: Apply to medical, military, aircraft, space or life support equipment and expressly waive any and all liability, including but not limited to special, consequential or collateral damage.

