

MKA03P2K5UK

P-Channel Enhancement Mode MOSFET

Features

- Low threshold voltage
- Built-in G-S Protection Diode
- Typical ESD Protection HBM Class 2

Classification	Voltage Range(V)
0A	< 125
0B	125 to < 250
1A	250 to < 500
1B	500 to < 1000
1C	1000 to < 2000
2	2000 to < 4000
3A	4000 to < 8000
3B	≥ 8000

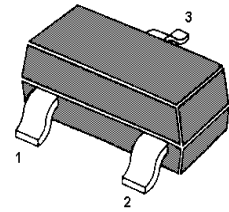
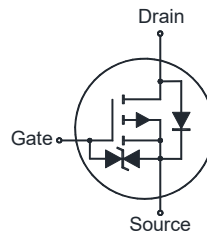

1. Gate 2. Source 3. Drain
SOT-23 Plastic Package

Applications

- Portable appliances

Absolute Maximum Ratings (at $T_a = 25^\circ\text{C}$ unless otherwise specified)

Parameter	Symbol	Value	Unit
Drain-Source Voltage	$-V_{DS}$	30	V
Gate-Source Voltage	V_{GS}	± 10	V
Drain Current	$-I_D$	360	mA
Peak Drain Current, Pulsed ¹⁾	$-I_{DM}$	1.4	A
Power Dissipation ²⁾	P_D	500	mW
Operating Junction Temperature	T_j	150	$^\circ\text{C}$
Storage Temperature Range	T_{stg}	- 55 to + 150	$^\circ\text{C}$

Thermal Characteristics

Parameter	Symbol	Max.	Unit
Thermal Resistance-Junction to Ambient ²⁾ Steady State	$R_{\theta JA}$	250	$^\circ\text{C}/\text{W}$

¹⁾ Pulse Test: Pulse Width $\leq 100 \mu\text{s}$, Duty Cycle $\leq 2\%$, Repetitive rating, pulse width limited by junction temperature $T_{j(\text{MAX})}=150^\circ\text{C}$.

²⁾ Device mounted on FR-4 substrate PC board, 2oz copper, with 1-inch square copper plate.

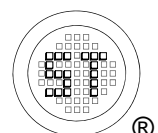

MKA03P2K5UK

Characteristics at $T_a = 25^\circ\text{C}$ unless otherwise specified

Parameter	Symbol	Min.	Typ.	Max.	Unit
STATIC PARAMETERS					
Drain-Source Breakdown Voltage at $-I_D = 250 \mu\text{A}$	$-V_{(BR)DSS}$	30	-	-	V
Zero Gate Voltage Drain Current at $-V_{DS} = 24 \text{ V}$	$-I_{DSS}$	-	-	1	μA
Gate-Source Leakage at $V_{GS} = \pm 8 \text{ V}$	I_{GSS}	-	-	± 10	μA
Gate-Source Threshold Voltage at $V_{DS} = V_{GS}$, $-I_D = 250 \mu\text{A}$	$-V_{GS(th)}$	0.4	-	1.0	V
Drain-Source On-State Resistance at $-V_{GS} = 4.5 \text{ V}$, $-I_D = 0.3 \text{ A}$ at $-V_{GS} = 2.5 \text{ V}$, $-I_D = 0.2 \text{ A}$ at $-V_{GS} = 1.8 \text{ V}$, $-I_D = 0.1 \text{ A}$	$R_{DS(on)}$	- - -	- - -	2.5 2.9 5	Ω
DYNAMIC PARAMETERS					
Input Capacitance at $-V_{DS} = 10 \text{ V}$, $V_{GS} = 0 \text{ V}$, $f = 1 \text{ MHz}$	C_{iss}	-	50	-	pF
Output Capacitance at $-V_{DS} = 10 \text{ V}$, $V_{GS} = 0 \text{ V}$, $f = 1 \text{ MHz}$	C_{oss}	-	6	-	pF
Reverse Transfer Capacitance at $-V_{DS} = 10 \text{ V}$, $V_{GS} = 0 \text{ V}$, $f = 1 \text{ MHz}$	C_{rss}	-	5	-	pF
Total Gate Charge at $-V_{DS} = 10 \text{ V}$, $-V_{GS} = 4.5 \text{ V}$, $-I_D = 0.1 \text{ A}$ at $-V_{DS} = 10 \text{ V}$, $-V_{GS} = 2.5 \text{ V}$, $-I_D = 0.1 \text{ A}$	Q_g	- -	1.22 0.8	- -	nC
Gate-Source Charge at $-V_{DS} = 10 \text{ V}$, $-V_{GS} = 4.5 \text{ V}$, $-I_D = 0.1 \text{ A}$	Q_{gs}	-	0.33	-	nC
Gate-Drain Charge at $-V_{DS} = 10 \text{ V}$, $-V_{GS} = 4.5 \text{ V}$, $-I_D = 0.1 \text{ A}$	Q_{gd}	-	0.22	-	nC
Turn-On Delay Time at $-V_{DD} = 10 \text{ V}$, $-V_{GS} = 4.5 \text{ V}$, $-I_D = 0.1 \text{ A}$, $R_G = 6 \Omega$	$t_{d(on)}$	-	3.4	-	ns
Turn-On Rise Time at $-V_{DD} = 10 \text{ V}$, $-V_{GS} = 4.5 \text{ V}$, $-I_D = 0.1 \text{ A}$, $R_G = 6 \Omega$	t_r	-	13	-	ns
Turn-Off Delay Time at $-V_{DD} = 10 \text{ V}$, $-V_{GS} = 4.5 \text{ V}$, $-I_D = 0.1 \text{ A}$, $R_G = 6 \Omega$	$t_{d(off)}$	-	37	-	ns
Turn-Off Fall Time at $-V_{DD} = 10 \text{ V}$, $-V_{GS} = 4.5 \text{ V}$, $-I_D = 0.1 \text{ A}$, $R_G = 6 \Omega$	t_f	-	23	-	ns
Body-Diode PARAMETERS					
Body Diode Voltage at $-I_S = 0.3 \text{ A}$	$-V_{SD}$	-	-	1.3	V
Body-Diode Continuous Current	$-I_S$	-	-	360	mA
Body Diode Reverse Recovery Time at $-I_S = 0.1 \text{ A}$, $di/dt = 100 \text{ A} / \mu\text{s}$	t_{rr}	-	42	-	ns
Body Diode Reverse Recovery Charge at $-I_S = 0.1 \text{ A}$, $di/dt = 100 \text{ A} / \mu\text{s}$	Q_{rr}	-	41	-	nC

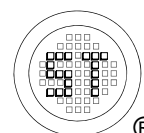

MKA03P2K5UK

Electrical Characteristics Curves

Output Characteristics

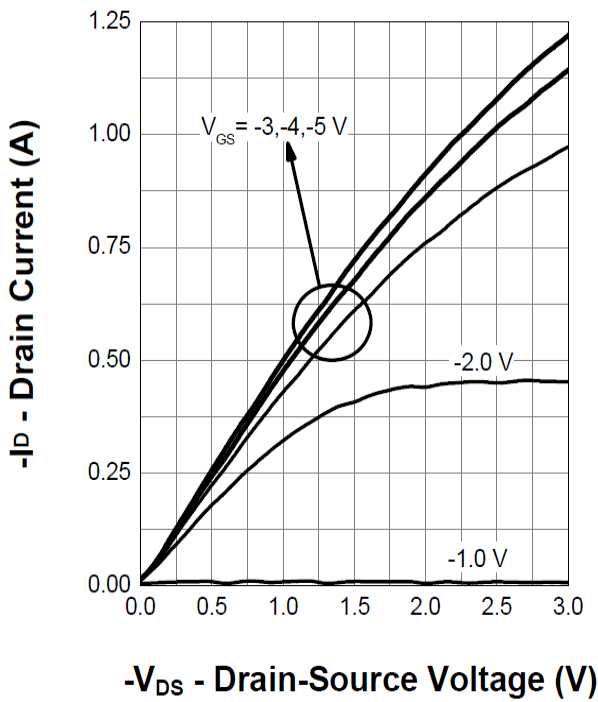

Drain-Source On Resistance

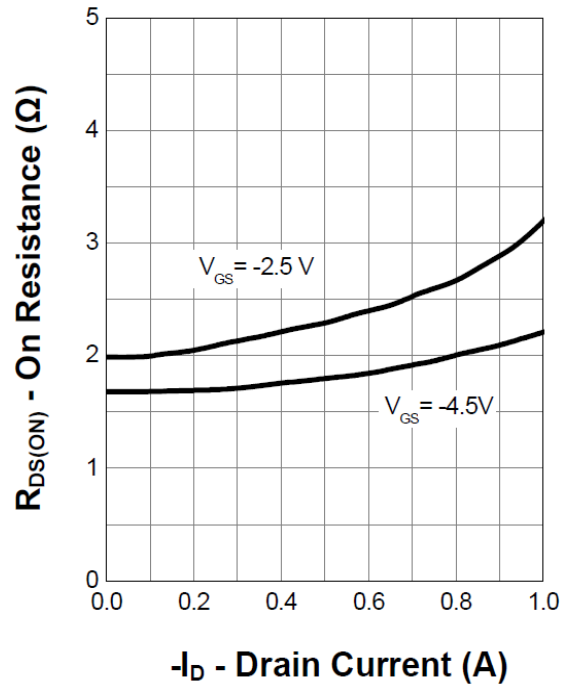

Transfer Characteristics

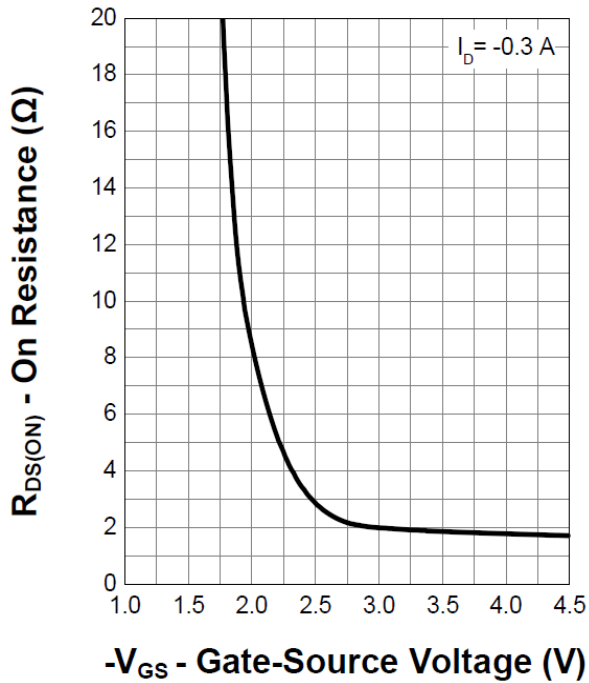

Gate Threshold Voltage

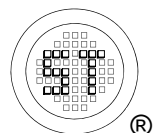
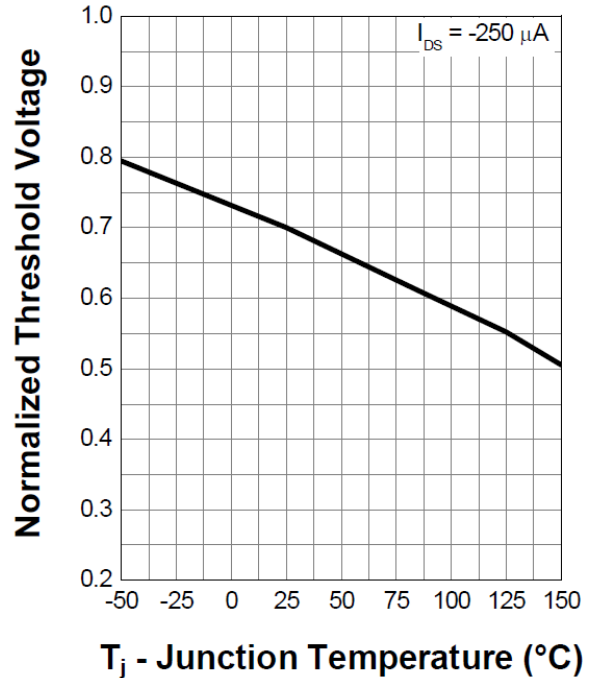

Electrical Characteristics Curves

Drain-Source On Resistance

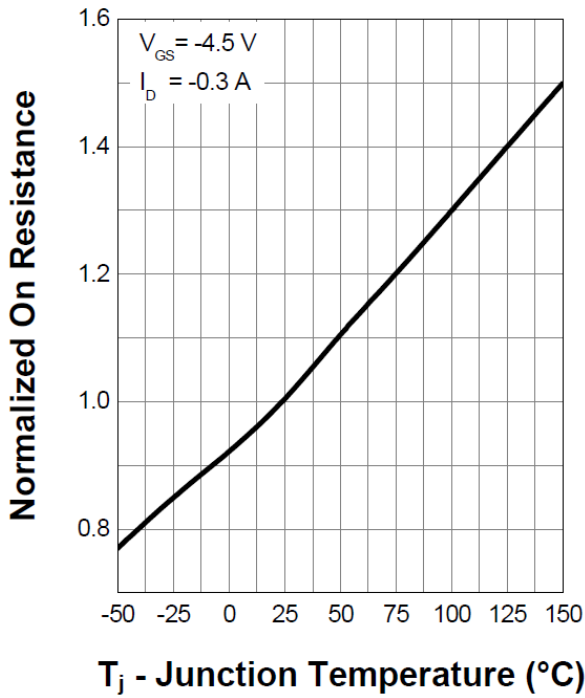

Source-Drain Diode Forward

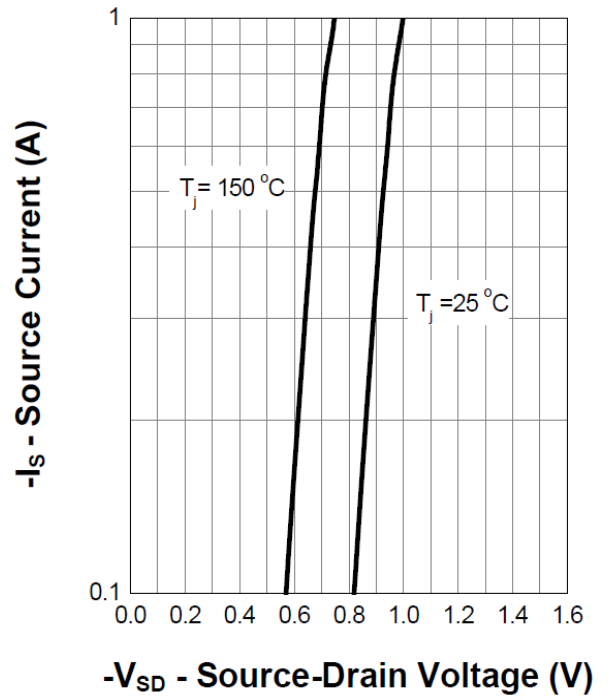

Capacitance

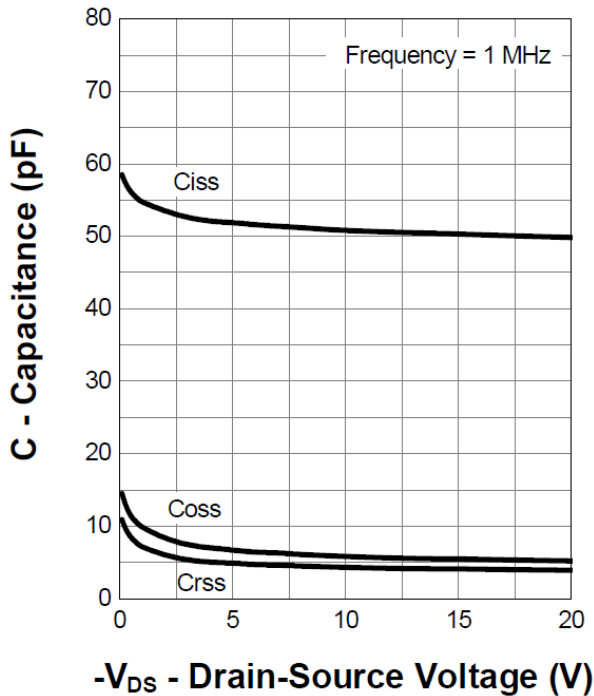

Gate Charge

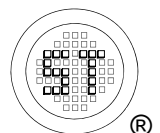
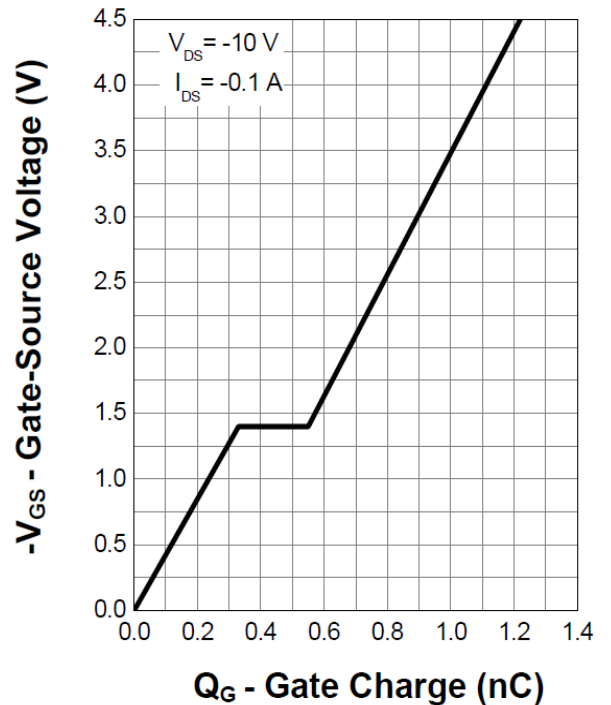

Test Circuits

Fig.1-1 Switching times test circuit

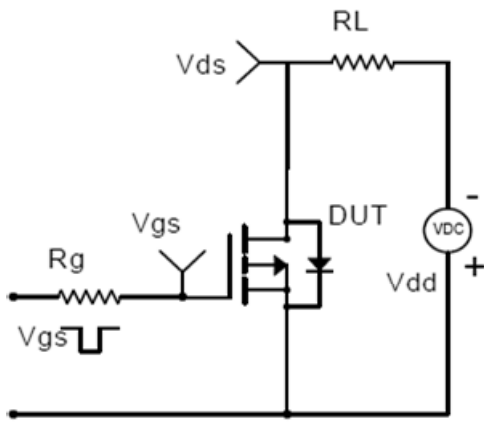

Fig.1-2 Switching Waveform

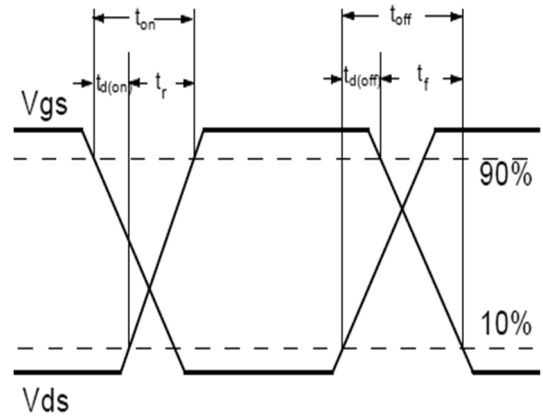

Fig.2-1 Gate charge test circuit

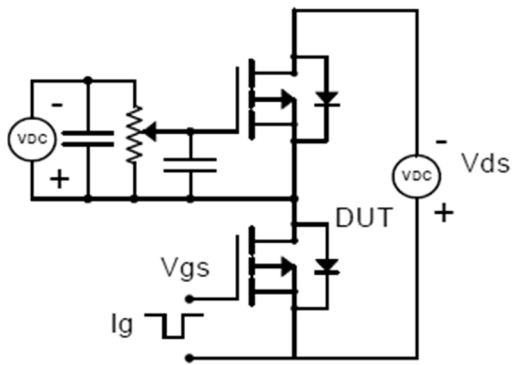
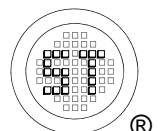
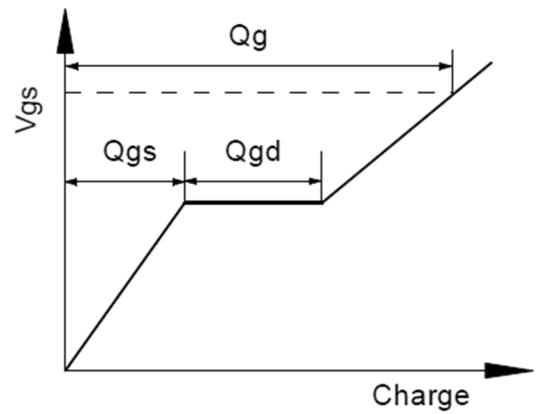

Fig.2-2 Gate charge waveform



MKA03P2K5UK

Package Outline (Dimensions in mm)

SOT-23

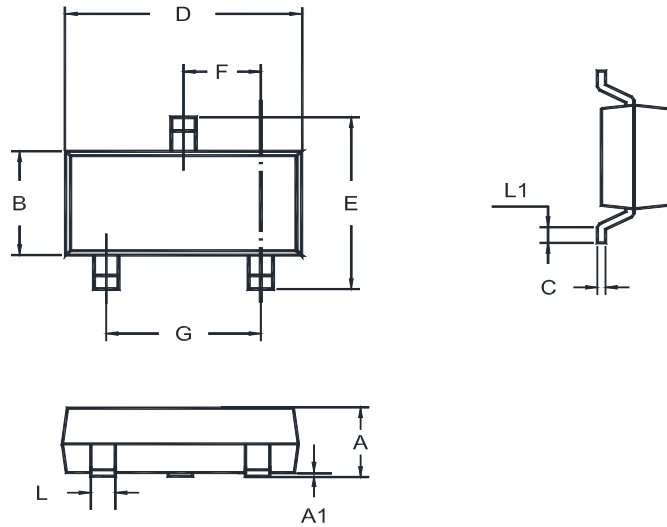

Unit	A	A1	B	C	D	E	F	G	L	L1
mm	1.20	0.100	1.40	0.19	3.04	2.6	1.02	2.04	0.51	0.2
	0.89	0.013	1.20	0.08	2.80	2.2	0.89	1.78	0.37	MIN

Recommended Soldering Footprint

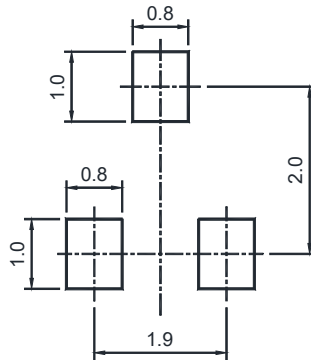

Packing information

Package	Tape Width (mm)	Pitch		Reel Size		Per Reel Packing Quantity
		mm	inch	mm	inch	
SOT-23	8	4 ± 0.1	0.157 ± 0.004	178	7	3,000

Marking information

- " TB " = Part No.
 - " YM " = Date Code Marking
 - " Y " = Year
 - " M " = Month
- Font type: Arial

