

# MKA02P041UK

## P-Channel Enhancement Mode MOSFET

### Features

- Extremely low threshold voltage
- Built-in G-S Protection Diode
- Typical ESD Protection HBM Class 1C

Classification	Voltage Range(V)
0A	< 125
0B	125 to < 250
1A	250 to < 500
1B	500 to < 1000
1C	1000 to < 2000
2	2000 to < 4000
3A	4000 to < 8000
3B	$\geq 8000$

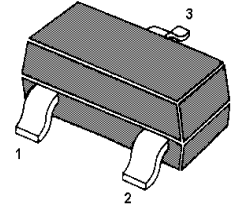
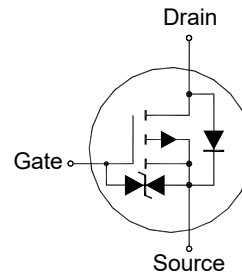

1. Gate 2. Source 3. Drain  
SOT-23 Plastic Package

### Applications

- Portable appliances
- Battery management
- High speed switch
- Low power DC to DC Converter

### Absolute Maximum Ratings(at $T_a = 25^\circ\text{C}$ unless otherwise specified)

Parameter	Symbol	Value	Unit
Drain-Source Voltage	$-V_{DS}$	20	V
Gate-Source Voltage	$V_{GS}$	$\pm 8$	V
Drain Current	$-I_D$	5	A
Peak Drain Current, Pulsed <sup>1)</sup>	$-I_{DM}$	30	A
Power Dissipation <sup>2)</sup>	$P_D$	1.5	W
Operating Junction and Storage Temperature Range	$T_j, T_{stg}$	- 55 to + 150	$^\circ\text{C}$

### Thermal Characteristics

Parameter	Symbol	Max.	Unit
Thermal Resistance - Junction to Ambient <sup>2)</sup>	$R_{\theta JA}$	80 100	$^\circ\text{C/W}$

<sup>1)</sup> Pulse Test: Pulse Width  $\leq 100 \mu\text{s}$ , Duty Cycle  $\leq 2\%$ , Repetitive rating, pulse width limited by junction temperature  $T_{j(\text{MAX})} = 150^\circ\text{C}$ .

<sup>2)</sup> Device mounted on FR-4 substrate PC board, 2oz copper, with 1-inch square copper plate.

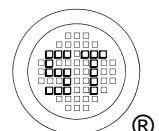

# MKA02P041UK

Characteristics at  $T_a = 25^\circ\text{C}$  unless otherwise specified

Parameter	Symbol	Min.	Typ.	Max.	Unit
<b>STATIC PARAMETERS</b>					
Drain-Source Breakdown Voltage at $-I_D = 250 \mu\text{A}$	$-V_{(BR)DSS}$	20	-	-	V
Gate Voltage Drain Current at $-V_{DS} = 16 \text{ V}$	$-I_{DSS}$	-	-	1	$\mu\text{A}$
Gate-Source Leakage at $V_{GS} = \pm 8 \text{ V}$	$I_{GSS}$	-	-	$\pm 10$	$\mu\text{A}$
Gate-Source Threshold Voltage at $V_{DS} = V_{GS}$ , $-I_D = 250 \mu\text{A}$	$-V_{GS(th)}$	0.3	-	1	V
Drain-Source On-State Resistance at $-V_{GS} = 4.5 \text{ V}$ , $-I_D = 4 \text{ A}$ at $-V_{GS} = 2.5 \text{ V}$ , $-I_D = 4 \text{ A}$ at $-V_{GS} = 1.8 \text{ V}$ , $-I_D = 2 \text{ A}$	$R_{DS(on)}$	-	-	41 53 75	$\text{m}\Omega$
<b>DYNAMIC PARAMETERS</b>					
Input Capacitance at $-V_{DS} = 10 \text{ V}$ , $V_{GS} = 0 \text{ V}$ , $f = 1 \text{ MHz}$	$C_{iss}$	-	1121	-	pF
Output Capacitance at $-V_{DS} = 10 \text{ V}$ , $V_{GS} = 0 \text{ V}$ , $f = 1 \text{ MHz}$	$C_{oss}$	-	161	-	pF
Reverse Transfer Capacitance at $-V_{DS} = 10 \text{ V}$ , $V_{GS} = 0 \text{ V}$ , $f = 1 \text{ MHz}$	$C_{rss}$	-	148	-	pF
Total Gate Charge at $-V_{DS} = 10 \text{ V}$ , $-V_{GS} = 4.5 \text{ V}$ , $-I_D = 4 \text{ A}$ at $-V_{DS} = 10 \text{ V}$ , $-V_{GS} = 2.5 \text{ V}$ , $-I_D = 4 \text{ A}$	$Q_g$	-	17.4 10	-	nC
Gate-Source Charge at $-V_{DS} = 10 \text{ V}$ , $-V_{GS} = 4.5 \text{ V}$ , $-I_D = 4 \text{ A}$	$Q_{gs}$	-	1.9	-	nC
Gate-Drain Charge at $-V_{DS} = 10 \text{ V}$ , $-V_{GS} = 4.5 \text{ V}$ , $-I_D = 4 \text{ A}$	$Q_{gd}$	-	4.1	-	nC
Turn-On Delay Time at $-V_{DS} = 10 \text{ V}$ , $-V_{GS} = 4.5 \text{ V}$ , $-I_D = 4 \text{ A}$ , $R_g = 3.3 \Omega$	$t_{d(on)}$	-	5.5	-	nS
Turn-On Rise Time at $-V_{DS} = 10 \text{ V}$ , $-V_{GS} = 4.5 \text{ V}$ , $-I_D = 4 \text{ A}$ , $R_g = 3.3 \Omega$	$t_r$	-	60.5	-	nS
Turn-Off Delay Time at $-V_{DS} = 10 \text{ V}$ , $-V_{GS} = 4.5 \text{ V}$ , $-I_D = 4 \text{ A}$ , $R_g = 3.3 \Omega$	$t_{d(off)}$	-	89	-	nS
Turn-Off Fall Time at $-V_{DS} = 10 \text{ V}$ , $-V_{GS} = 4.5 \text{ V}$ , $-I_D = 4 \text{ A}$ , $R_g = 3.3 \Omega$	$t_f$	-	73	-	nS
<b>Body-Diode PARAMETERS</b>					
Drain-Source Diode Forward Voltage at $-I_s = 3 \text{ A}$	$-V_{SD}$	-	-	1.2	V
Body-Diode Continuous Current	$-I_s$	-	-	5	A
Body Diode Reverse Recovery Time at $-I_s = 4 \text{ A}$ , $di/dt = 100 \text{ A} / \mu\text{s}$	$t_{rr}$	-	49.5	-	nS
Body Diode Reverse Recovery Charge at $-I_s = 4 \text{ A}$ , $di/dt = 100 \text{ A} / \mu\text{s}$	$Q_{rr}$	-	16.5	-	nC

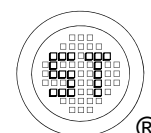

## Electrical characteristics curves

Fig. 1 Typical Output Characteristics

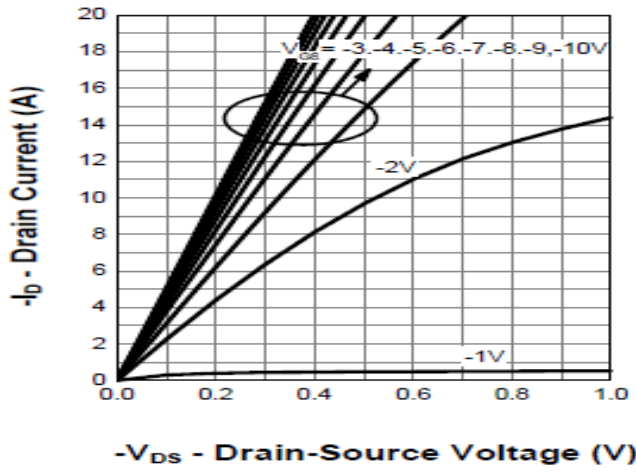

Fig. 2 Gate Threshold Variation vs.  $T_j$

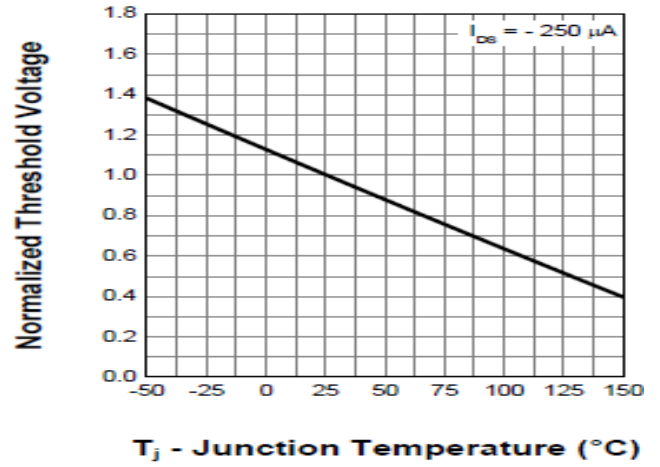

Fig. 3 Typical Transfer Characteristics

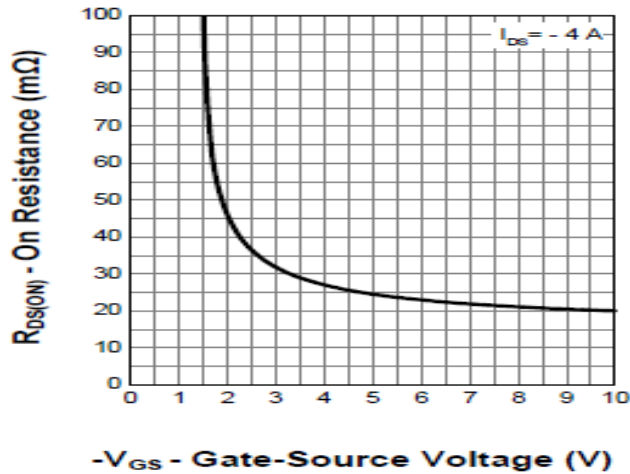

Fig. 4 on-Resistance vs.  $T_j$

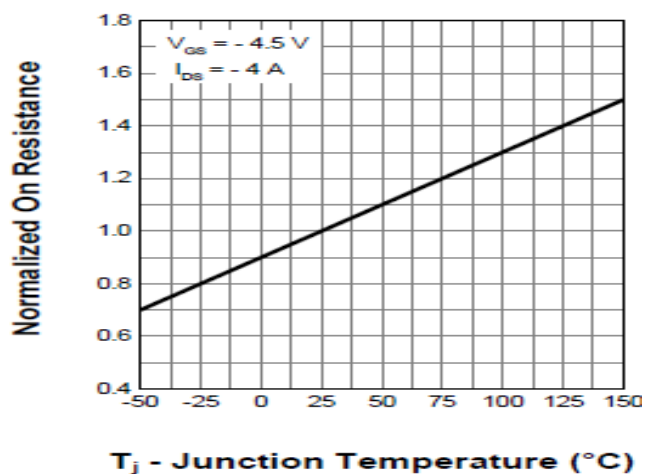

Fig. 5 on-Resistance vs. Drain Current

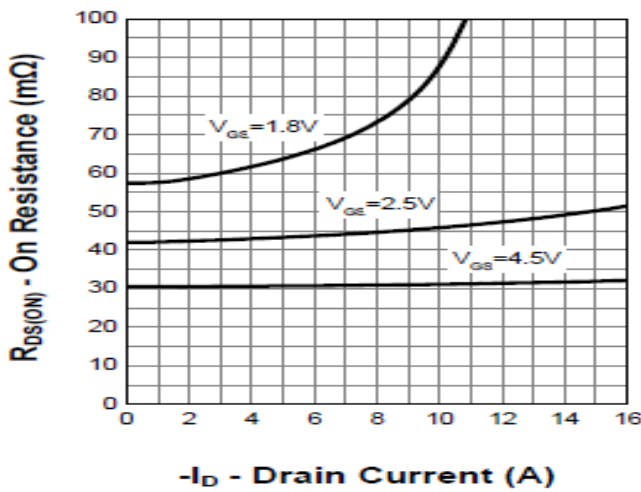
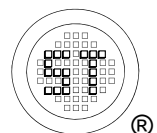
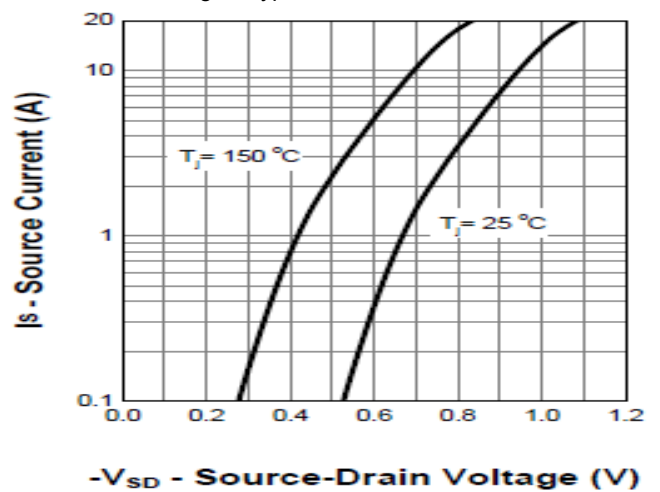

Fig. 6 Typical Forward Characteristics



## Electrical characteristics curves

Fig. 7 Typical Junction Capacitance

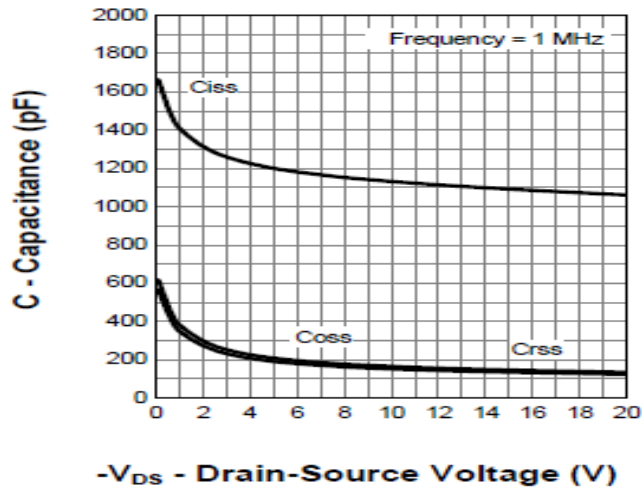
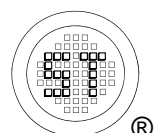
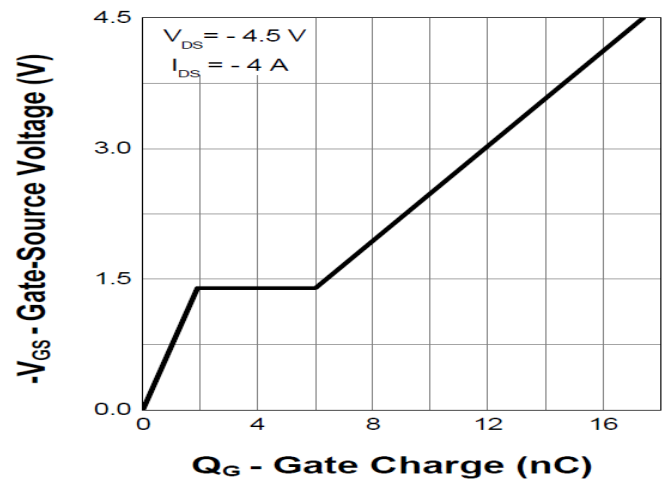

Fig. 8 Gate Charge



## Test Circuits

Fig.1-1 Switching times test circuit

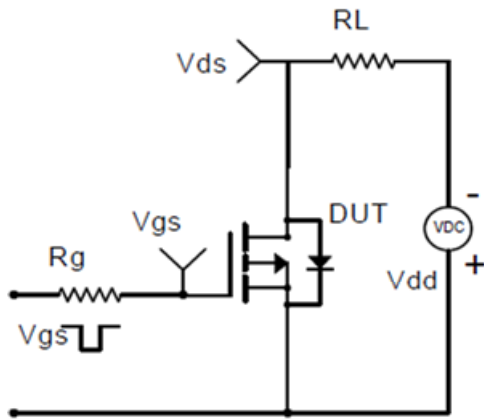

Fig.1-2 Switching Waveform

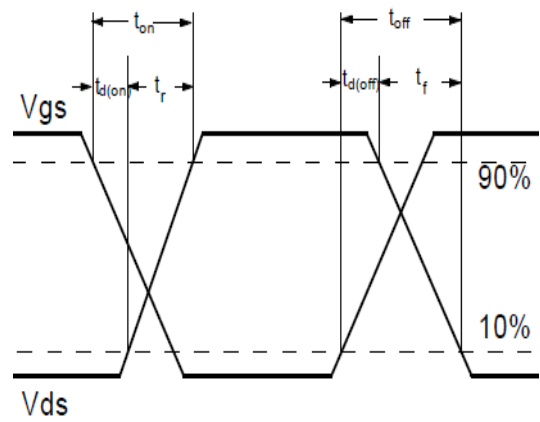

Fig.2-1 Gate charge test circuit

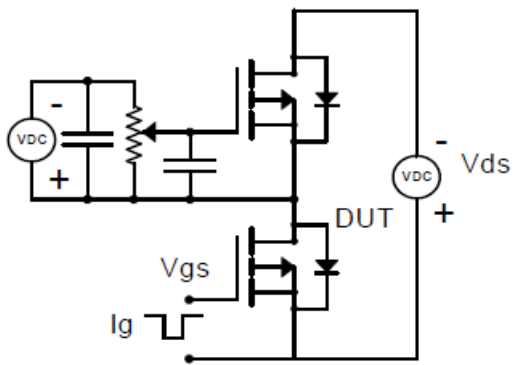
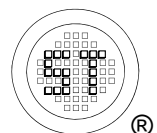
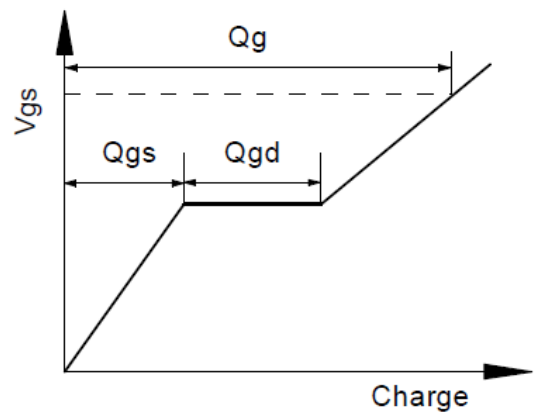

Fig.2-2 Gate charge waveform



# MKA02P041UK

## Package Outline (Dimensions in mm)

SOT-23

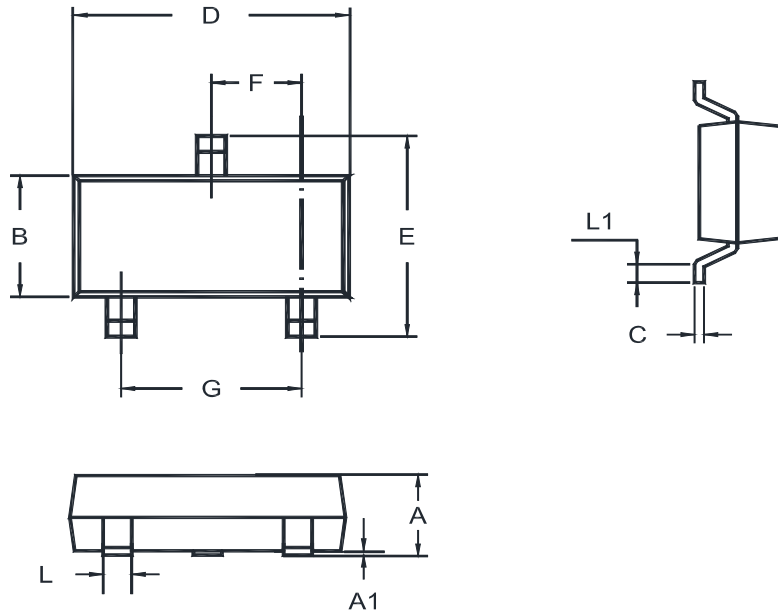

Unit	A	A1	B	C	D	E	F	G	L	L1
mm	1.20	0.100	1.40	0.19	3.04	2.6	1.02	2.04	0.51	0.2
	0.89	0.013	1.20	0.08	2.80	2.2	0.89	1.78	0.37	MIN

## Recommended Soldering Footprint

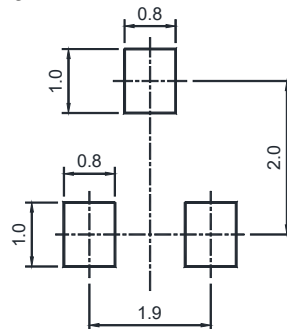

## Packing information

Package	Tape Width (mm)	Pitch		Reel Size		Per Reel Packing Quantity
		mm	inch	mm	inch	
SOT-23	8	4 ± 0.1	0.157 ± 0.004	178	7	3,000

## Marking information

" MG " = Part No.  
 "YM" = Date Code Marking  
 "Y" = Year  
 "M" = Month  
 Font type: Arial

