

# KDS114WT

## Silicon Epitaxial Planar Band Switch Diode

### Features

- Small package
- Small total capacitance
- Low series resistance
- Low leakage current

### Application

- For VHF tuner band switch applications

### PINNING

PIN	DESCRIPTION
1	Cathode
2	Anode

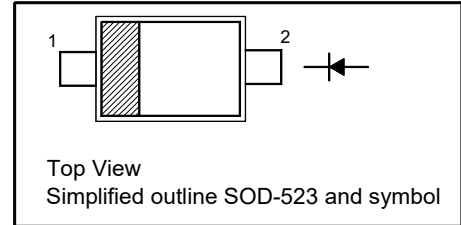

### Absolute Maximum Ratings ( $T_a = 25^\circ\text{C}$ )

Parameter	Symbol	Value	Unit
Reverse Voltage	$V_R$	35	V
Forward Current	$I_F$	100	mA
Junction Temperature	$T_J$	125	$^\circ\text{C}$
Storage Temperature Range	$T_{stg}$	- 55 to + 125	$^\circ\text{C}$

### Characteristics at $T_a = 25^\circ\text{C}$

Parameter	Symbol	Min.	Max.	Unit
Forward Voltage at $I_F = 2\text{ mA}$	$V_F$	-	0.85	V
Reverse Current at $V_R = 15\text{ V}$	$I_R$	-	100	nA
Reverse Voltage at $I_R = 10\text{ }\mu\text{A}$	$V_R$	35	-	V
Total Capacitance at $V_R = 6\text{ V}$ , $f = 1\text{ MHz}$	$C_T$	-	1.2	pF
Series Resistance at $I_F = 2\text{ mA}$ , $f = 100\text{ MHz}$	$r_s$	-	0.9	$\Omega$

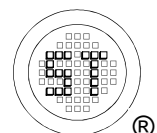

## Electrical Characteristics Curves

Fig 1.  $r_s$  vs.  $I_F$  Curve

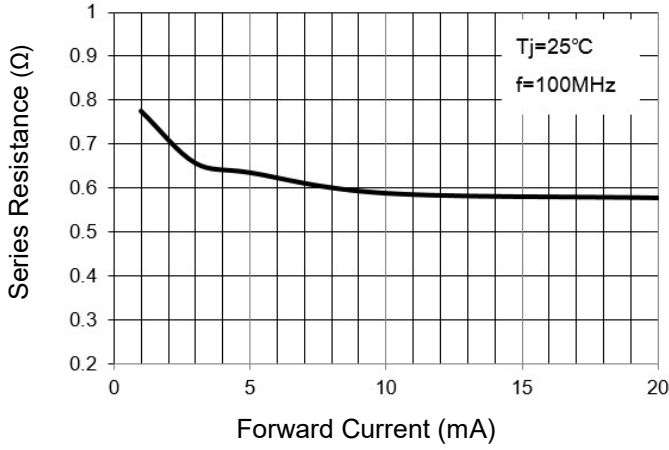

Fig 2. Forward Characteristic Curve

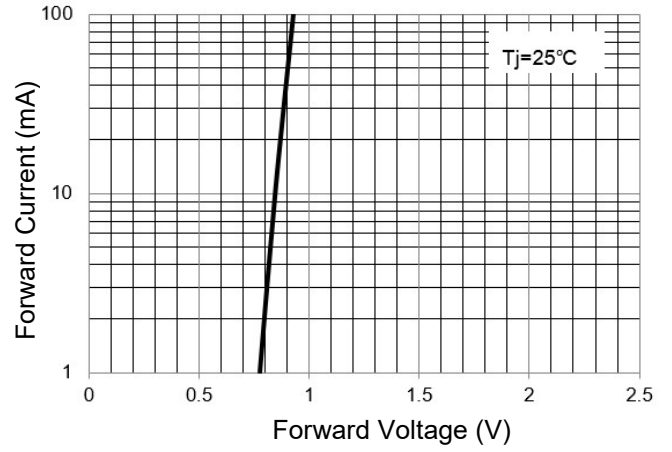

Fig 3. Junction Capacitance

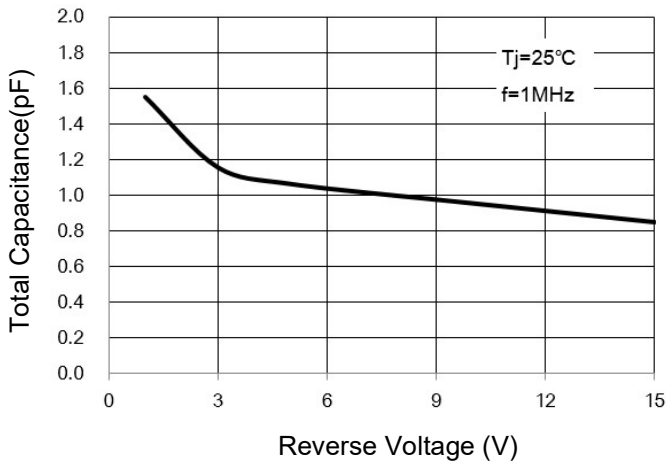
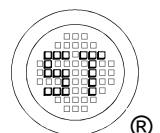
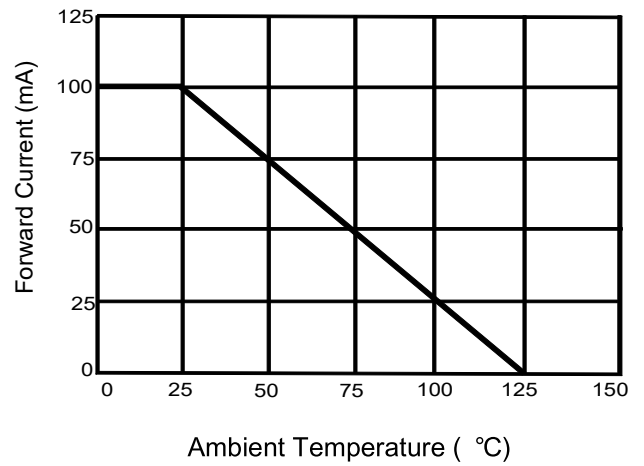

Fig 4. Forward Current Derating Curve



# KDS114WT

## PACKAGE OUTLINE

Plastic surface mounted package

SOD-523

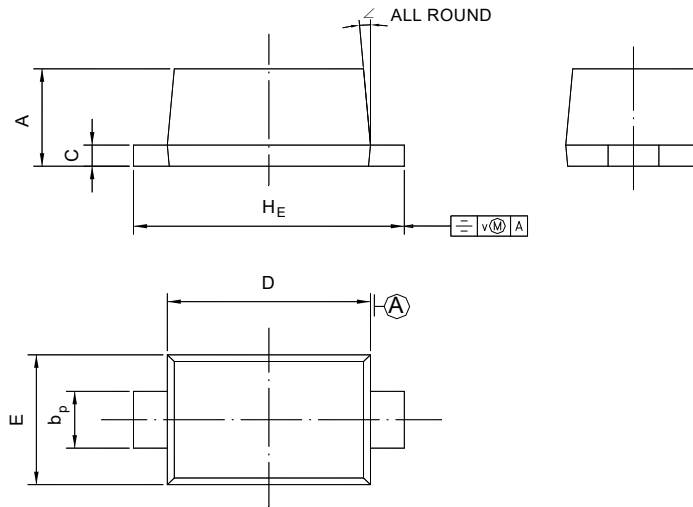

UNIT	A	b <sub>p</sub>	C	D	E	H <sub>E</sub>	V	∠
mm	0.70 0.60	0.4 0.3	0.135 0.100	1.25 1.15	0.85 0.75	1.7 1.5	0.1	5°

## Recommended Soldering Footprint

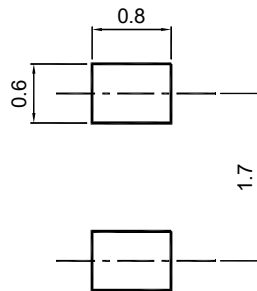

## Packing information

Package	Tape Width (mm)	Pitch		Reel Size		Per Reel Packing Quantity
		mm	inch	mm	inch	
SOD-523	8	4 ± 0.1	0.157 ± 0.004	178	7	4,000

## Marking information

" W7 " = Part No.

" III " = Cathode line

Font type: Arial



Disclaimer: Our company reserve the right to make modifications, enhancements, improvements, corrections or other changes to improve product design, functions and reliability, anytime without notice. Semtech Electronics Limited makes no warranties, representations or warranties regarding the suitability of its products for any particular purpose, and does not accept any liability arising from the application or use of any product or circuit such as: Apply to medical, military, aircraft, space or life support equipment and expressly waive any and all liability, including but not limited to special, consequential or collateral damage.

