

ES2ABF THRU ES2JBF

Surface Mount Superfast Recovery Rectifier

Reverse Voltage - 50 to 600 V

Forward Current - 2 A

Features

- Glass Passivated Chip Junction
- For surface mounted applications
- Low profile package
- Superfast reverse recovery time

Mechanical Data

- **Case:** SMBF
- **Terminals:** Solderable per MIL-STD-750, Method 2026

PINNING

PIN	DESCRIPTION
1	Cathode
2	Anode

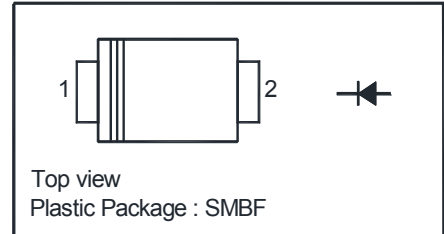

Absolute Maximum Ratings and Characteristics

Ratings at 25°C ambient temperature unless otherwise specified.

Single phase half-wave 60 Hz, resistive or inductive load, for capacitive load current derate by 20%.

Parameter	Symbols	ES2ABF	ES2BBF	ES2CBF	ES2DBF	ES2EBF	ES2GBF	ES2JBF	Units
Maximum Repetitive Peak Reverse Voltage	V_{RRM}	50	100	150	200	300	400	600	V
Maximum RMS Voltage	V_{RMS}	35	70	105	140	210	280	420	V
Maximum DC Blocking Voltage	V_{DC}	50	100	150	200	300	400	600	V
Maximum Average Forward Rectified Current at $T_c = 125^\circ\text{C}$	$I_{F(AV)}$	2							A
Peak Forward Surge Current 8.3 ms Single Half Sine Wave Superimposed on Rated Load (JEDEC Method)	I_{FSM}	50							A
Maximum Forward Voltage at 2 A	V_F	1				1.25		1.65	V
Maximum Reverse Current at Rated DC Blocking Voltage $T_j = 25^\circ\text{C}$ $T_j = 125^\circ\text{C}$	I_R					5		100	μA
Typical Junction Capacitance at $V_R = 4\text{ V}$, $f = 1\text{ MHz}$	C_j					28			pF
Maximum Reverse Recovery Time at $I_F = 0.5\text{ A}$, $I_R = 1\text{ A}$, $I_{rr} = 0.25\text{ A}$	t_{rr}					35			ns
Typical Thermal Resistance ¹⁾	$R_{\theta JA}$ $R_{\theta JC}$					60		18	$^\circ\text{C/W}$
Operating Junction and Storage Temperature Range	T_j , T_{stg}	- 55 to + 150							$^\circ\text{C}$

¹⁾ P.C.B. mounted with 2.0" X 2.0" (5 X 5 cm) copper pad areas.

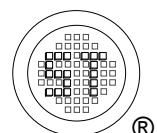

ES2ABF THRU ES2JBF

Electrical Characteristics Curves

Fig.1 Reverse Recovery Time Characteristic And Test Circuit Diagram

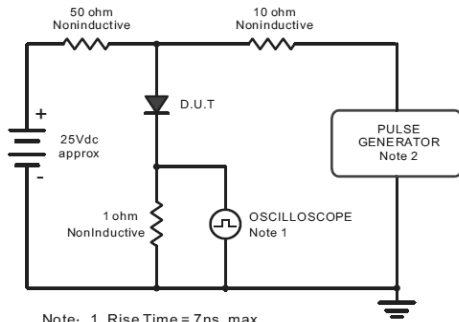

Note: 1. Rise Time = 7ns, max.
Input Impedance = 1megohm, 22pF.
2. Rise Time = 10ns, max.
Source Impedance = 50 ohms.

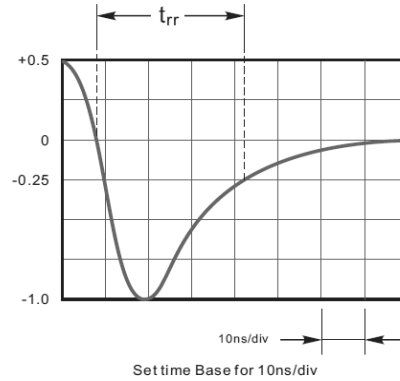

Fig.2 Maximum Average Forward Current Rating

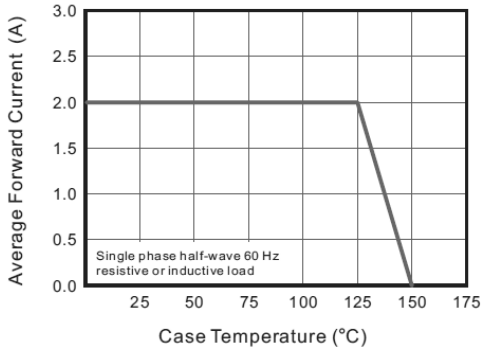

Fig.3 Typical Reverse Characteristics

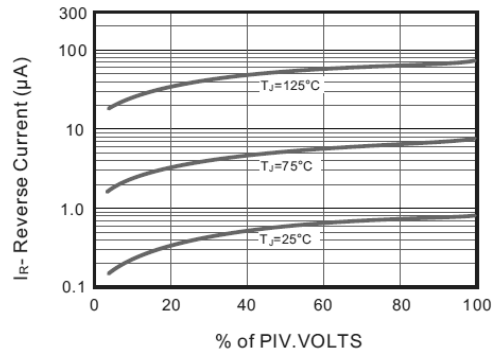

Fig.4 Typical Forward Characteristics

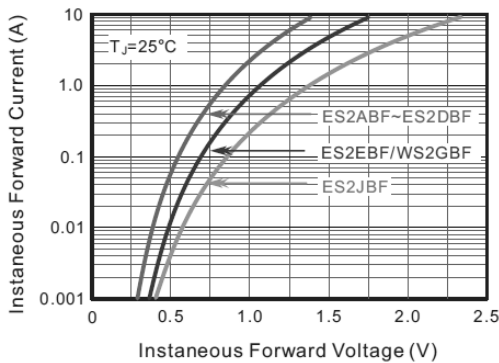

Fig.5 Typical Junction Capacitance

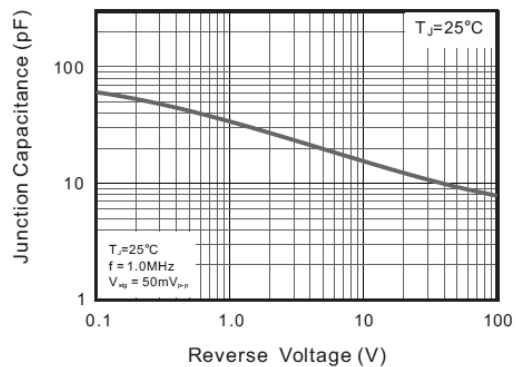
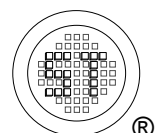
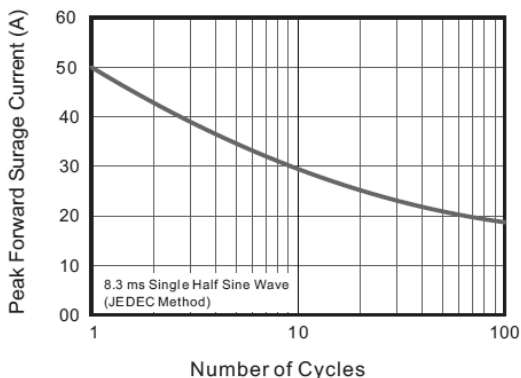

Fig.6 Maximum Non-Repetitive Peak Forward Surge Current



ES2ABF THRU ES2JBF

Package Outline Dimensions (Units: mm)

SMBF

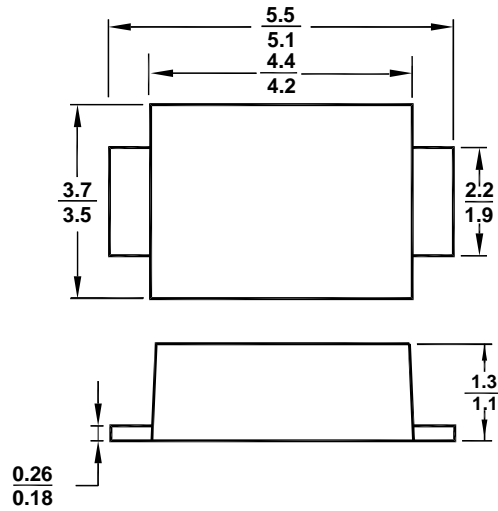

Recommended Soldering Footprint

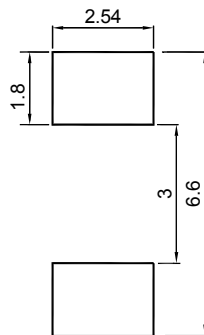

Marking information

" **** " = Part No.

ES2ABF : E2AB

ES2BBF : E2BB

ES2CBF : E2CB

ES2DBF : E2DB

ES2EBF : E2EB

ES2GBF : E2GB

ES2JBF : E2JB

" III " = Cathode line

Font type: Arial

