

BCX51U

PNP Silicon Epitaxial Planar Power Transistor

Features

- Low Saturation Voltage $V_{CE(sat)}$
- Epitaxial Planar Die Construction

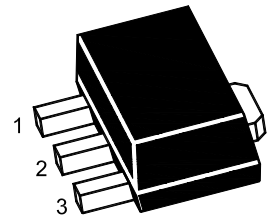

1.Base 2.Collector 3.Emitter
SOT-89 Plastic Package

Applications

- Medium Power Switching or Amplification Applications
- AF driver and output stages

Absolute Maximum Ratings

Parameter	Symbol	Value	Unit
Collector Base Voltage	$-V_{CBO}$	45	V
Collector Emitter Voltage	$-V_{CEO}$	45	V
Emitter Base Voltage	$-V_{EBO}$	5	V
Collector Current	$-I_C$	1	A
Peak Collector Current, Pulsed	$-I_{CM}$	1.5	A
Total Power Dissipation	P_{tot}	1	W
Junction Temperature	T_j	150	°C
Storage Temperature Range	T_{stg}	- 55 to + 150	°C

Thermal Characteristics

Parameter	Symbol	Max.	Unit
Thermal Resistance from Junction to Ambient ¹⁾	$R_{\theta JA}$	125	°C/W

¹⁾ Device mounted on FR-4 substrate PC board, 2oz copper, with 1-inch square copper plate in still air.

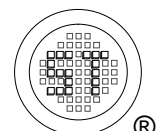

BCX51U

Characteristics at $T_a = 25^\circ\text{C}$

Parameter	Symbol	Min.	Typ.	Max.	Unit
DC Current Gain at $-V_{CE} = 2\text{ V}$, $-I_C = 5\text{ mA}$	h_{FE}	25	-	-	-
at $-V_{CE} = 2\text{ V}$, $-I_C = 150\text{ mA}$	h_{FE}	63	-	160	-
BCX51-10U	h_{FE}	100	-	250	-
BCX51-16U	h_{FE}	25	-	-	-
Collector Base Breakdown Voltage at $-I_C = 100\text{ }\mu\text{A}$	$-V_{BR(CBO)}$	45	-	-	V
Collector Emitter Breakdown Voltage at $-I_C = 10\text{ mA}$	$-V_{BR(CEO)}$	45	-	-	V
Emitter Base Breakdown Voltage at $-I_E = 10\text{ }\mu\text{A}$	$-V_{BR(EBO)}$	5	-	-	V
Collector Base Cutoff Current at $-V_{CB} = 30\text{ V}$	$-I_{CBO}$	-	-	0.1	μA
Emitter Base Cutoff Current at $-V_{EB} = 4\text{ V}$	$-I_{EBO}$	-	-	20	nA
Collector Emitter Saturation Voltage at $-I_C = 0.5\text{ A}$, $-I_B = 50\text{ mA}$	$-V_{CE(sat)}$	-	-	500	mV
Base Emitter Turn-On Voltage at $-V_{CE} = 2\text{ V}$, $-I_C = 500\text{ mA}$	$-V_{BE(on)}$	-	-	1	V
Output Capacitance at $-V_{CB} = 10\text{ V}$, $f = 1\text{ MHz}$	C_{ob}	-	-	25	pF
Transition Frequency at $-V_{CE} = 10\text{ V}$, $-I_C = 50\text{ mA}$, $f = 100\text{ MHz}$	f_T	-	105	-	MHz

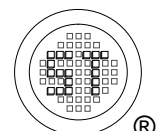

BCX51U

Electrical Characteristics Curves

Fig. 1 Power Derating Curve

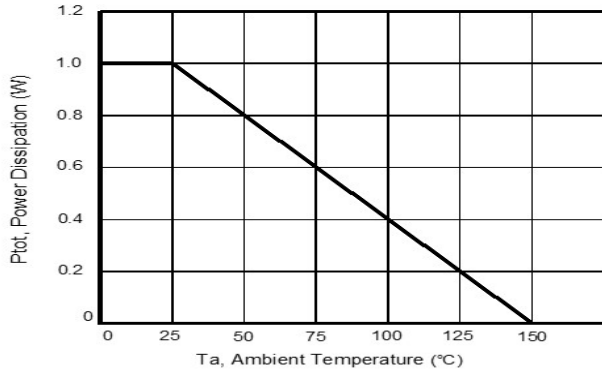

Fig. 2 $h_{FE,DC}$ Current Gain vs. Collector Current

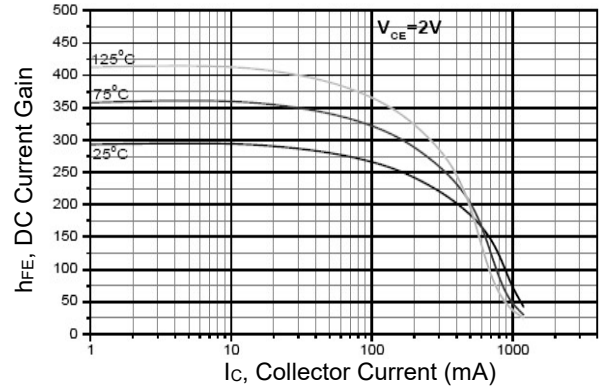

Fig. 3 $V_{BE(sat)}$ vs. Collector Current

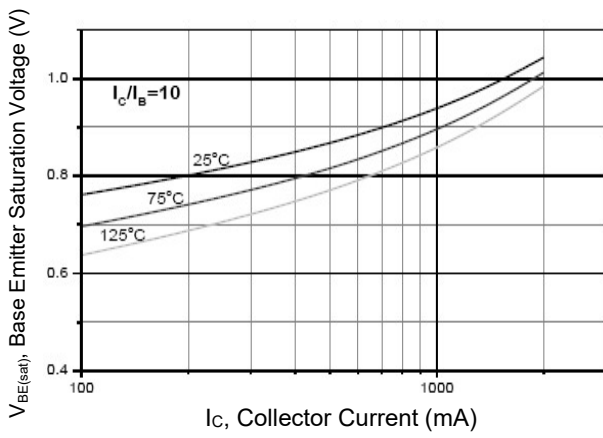
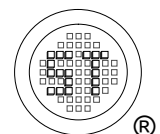
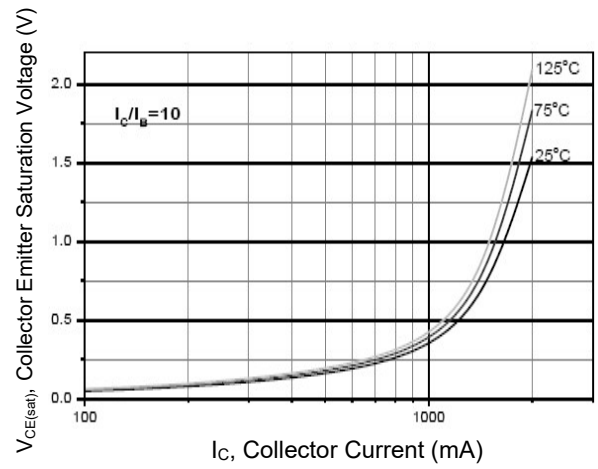

Fig. 4 $V_{CE(sat)}$ vs. Collector Current



BCX51U

Package Outline (Dimensions in mm)

SOT-89

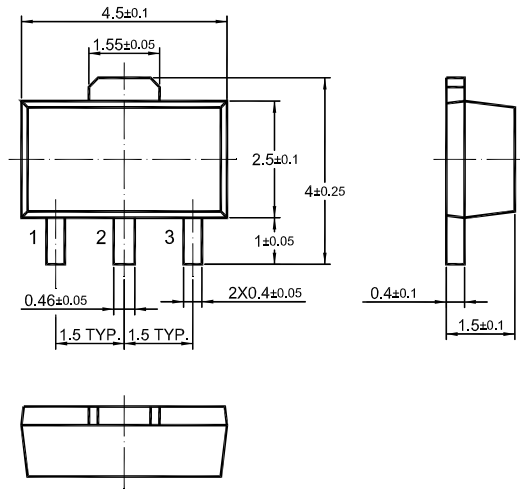

Recommended Soldering Footprint

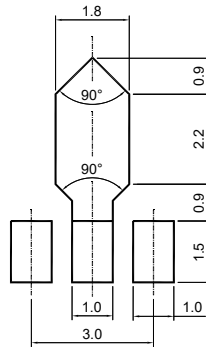

Packing information

Package	Tape Width (mm)	Pitch		Reel Size		Per Reel Packing Quantity
		mm	inch	mm	inch	
SOT-89	12	8 ± 0.1	0.315 ± 0.004	178	7	1,000
				330	13	4,000

Marking information

"BCX51-**U" = Part No. ("**" = HFE grouping Code)

"YM" = Date Code Marking

"Y" = Year

"M" = Month

Font type: Arial

