

BCP53Q-HAF

PNP Silicon Epitaxial Planar Power Transistor

Features

- Halogen and Antimony Free(HAF), RoHS compliant

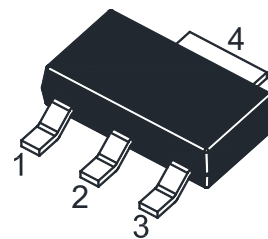

1.Base 2.Collector 3.Emitter 4. Collector
SOT-223 Plastic Package

Absolute Maximum Ratings ($T_a = 25^\circ\text{C}$)

Parameter	Symbol	Value	Unit
Collector Base Voltage	$-V_{\text{CBO}}$	100	V
Collector Emitter Voltage	$-V_{\text{CEO}}$	80	V
Emitter Base Voltage	$-V_{\text{EBO}}$	5	V
Collector Current	$-I_{\text{C}}$	1	A
Peak Collector Current	$-I_{\text{CM}}$	1.5	A
Peak Base Current	$-I_{\text{BM}}$	0.2	A
Total Power Dissipation	P_{tot}	1.3	W
Junction Temperature	T_{j}	150	$^\circ\text{C}$
Storage Temperature Range	T_{stg}	- 65 to + 150	$^\circ\text{C}$

Thermal Characteristics

Parameter	Symbol	Max.	Unit
Thermal Resistance from Junction to Ambient ¹⁾	$R_{\theta\text{JA}}$	96	$^\circ\text{C/W}$

¹⁾ Device mounted on FR-4 substrate PC board, 2oz copper, with 1-inch square copper plate.

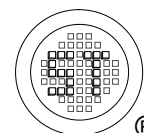

BCP53Q-HAF

Characteristics at $T_a = 25^\circ\text{C}$

Parameter	Symbol	Min.	Typ.	Max.	Unit
DC Current Gain at $-V_{CE} = 2\text{ V}$, $-I_C = 5\text{ mA}$ at $-V_{CE} = 2\text{ V}$, $-I_C = 500\text{ mA}$ at $-V_{CE} = 2\text{ V}$, $-I_C = 150\text{ mA}$	h_{FE}	40	-	-	-
	h_{FE}	25	-	-	-
	h_{FE}	63	-	160	-
	h_{FE}	100	-	250	-
Collector Base Cutoff Current at $-V_{CB} = 30\text{ V}$	$-I_{CBO}$	-	-	100	nA
Emitter Base Cutoff Current at $-V_{EB} = 5\text{ V}$	$-I_{EBO}$	-	-	100	nA
Collector Base Breakdown Voltage at $-I_C = 100\text{ }\mu\text{A}$	$-V_{(BR)CBO}$	100	-	-	V
Collector Emitter Breakdown Voltage at $-I_C = 10\text{ mA}$	$-V_{(BR)CEO}$	80	-	-	V
Emitter Base Breakdown Voltage at $-I_E = 10\text{ }\mu\text{A}$	$-V_{(BR)EBO}$	5	-	-	V
Collector Emitter Saturation Voltage at $-I_C = 500\text{ mA}$, $-I_B = 50\text{ mA}$	$-V_{CE(sat)}$	-	-	0.5	V
Base Emitter Voltage at $-V_{CE} = 2\text{ V}$, $-I_C = 500\text{ mA}$	$-V_{BE(on)}$	-	-	1	V
Transition Frequency at $-V_{CE} = 10\text{ V}$, $-I_C = 50\text{ mA}$, $f = 100\text{ MHz}$	f_T	-	125	-	MHz

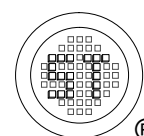

BCP53Q-HAF

Electrical Characteristics Curves

Fig. 1 Output Characteristics Curve

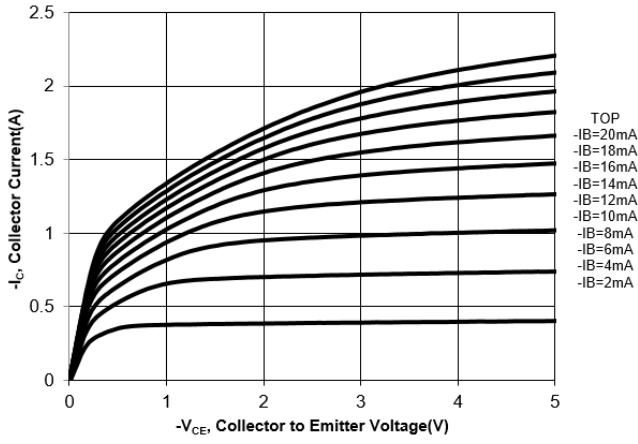

Fig. 2 Output Characteristics Curve

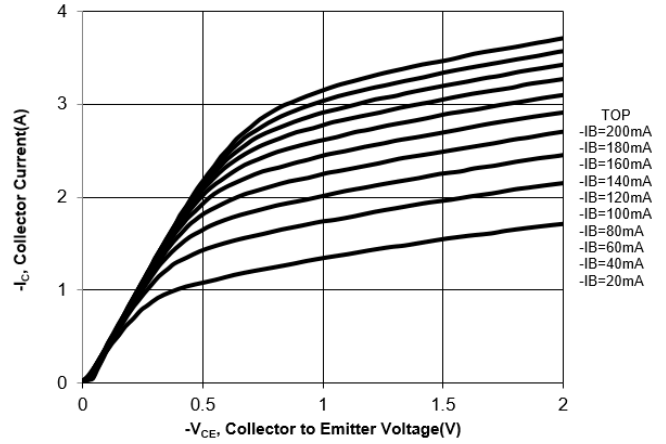

Fig. 3 Collector Current vs. Base to Emitter Voltage

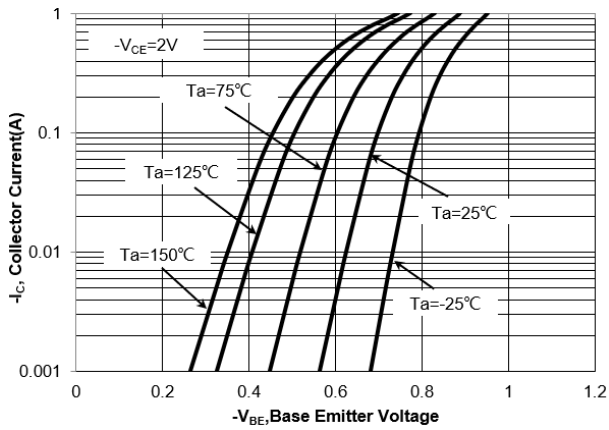
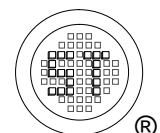
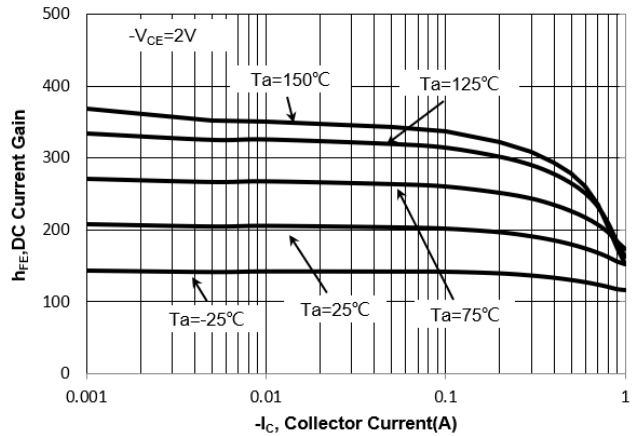

Fig. 4 $h_{FE,DC}$ Current Gain vs. Collector Current



BCP53Q-HAF

Electrical Characteristics Curves

Fig. 5 $V_{BE(SAT)}$ vs. Collector Current

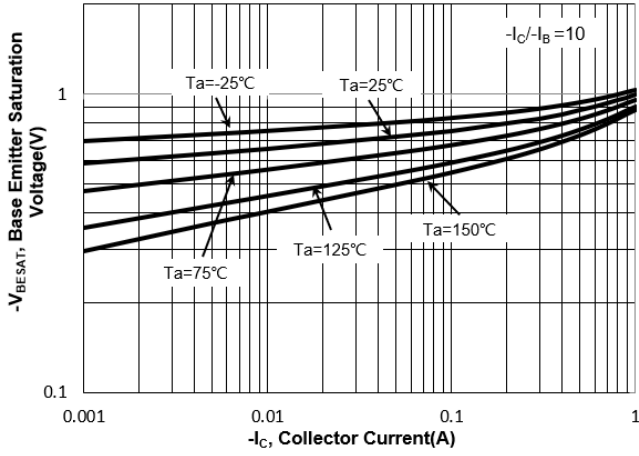

Fig. 6 $V_{CE(SAT)}$ vs. Collector Current

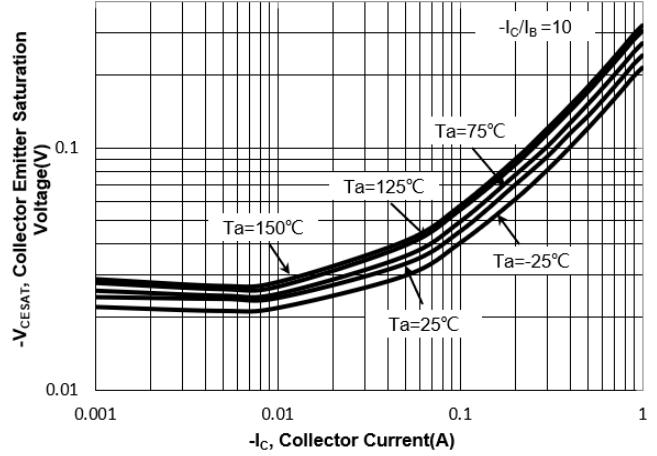

Fig. 7 Junction Capacitance

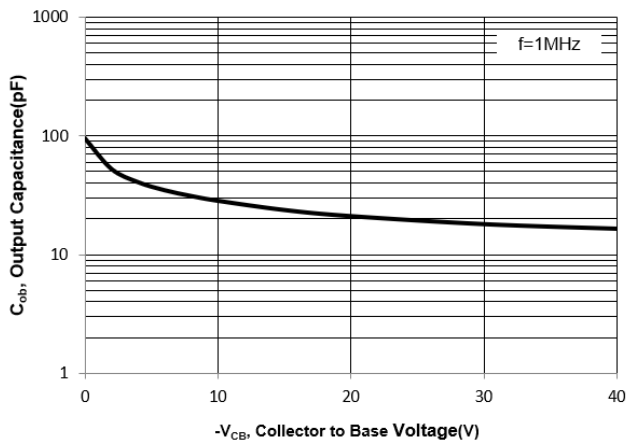
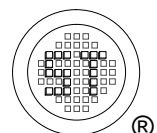
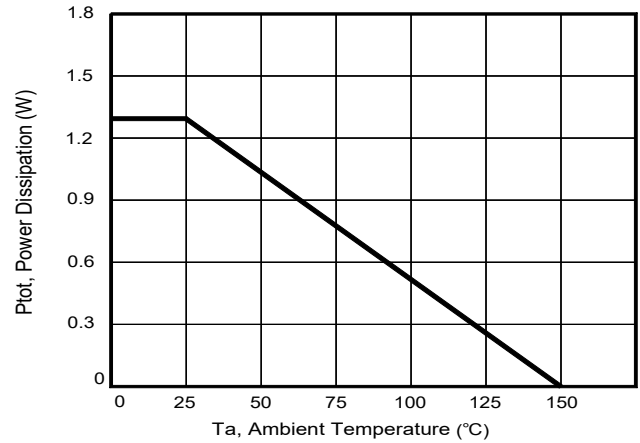

Fig. 8 Power Derating Curve



BCP53Q-HAF

Package Outline (Dimensions in mm)

SOT-223

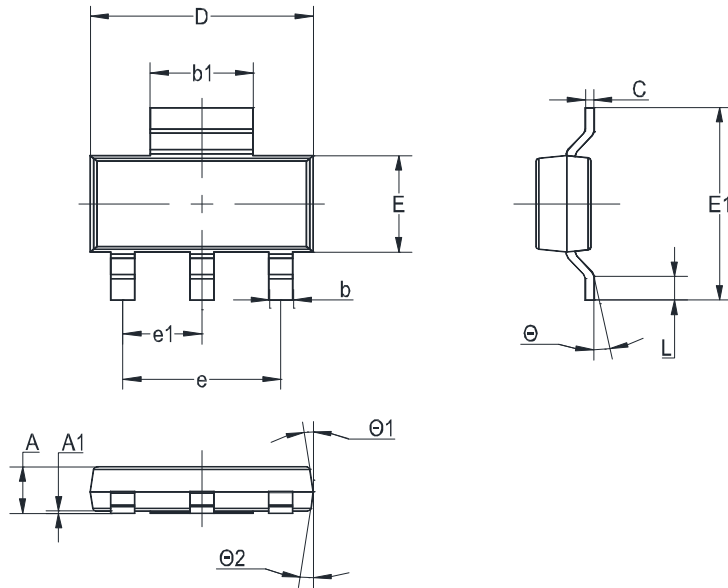

Unit	A	A1	b	b1	C	D	E	E1	e	e1	L	Θ	Θ1	Θ2
mm	1.8	0.1	0.8	3.1	0.32	6.7	3.7	7.3	4.6	2.3	1.1	10°	7°	7°
	1.5	MAX	0.6	2.9	0.22	6.3	3.3	6.7	TYP	TYP	0.7	0°	0°	0°

Recommended Soldering Footprint

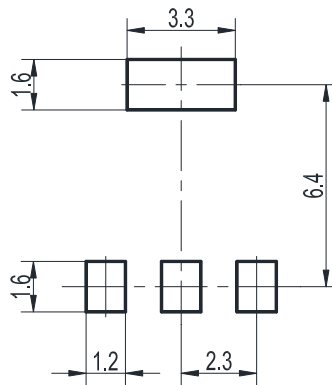

Packing information

Package	Tape Width (mm)	Pitch		Reel Size		Per Reel Packing Quantity
		mm	inch	mm	inch	
SOT-223	12	8 ± 0.1	0.315 ± 0.004	330	13	3,000

Marking information

" BCP53-*Q " = Part No. ("*" = HFE grouping Code)

" **** " = Date Code Marking

Font type: Arial

