

2SC1959

NPN Silicon Epitaxial Planar Transistor

Features

- The transistor is subdivided into three groups, O, Y and G, according to its DC current gain
- On special request, these transistors can be manufactured in different pin configurations

Applications

- For switching, driver stage and audio frequency low power amplifier applications

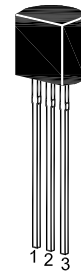

1. Emitter 2. Collector 3. Base
TO-92 Plastic Package

Absolute Maximum Ratings ($T_a = 25^\circ\text{C}$)

Parameter	Symbol	Value	Unit
Collector Base Voltage	V_{CBO}	35	V
Collector Emitter Voltage	V_{CEO}	30	V
Emitter Base Voltage	V_{EBO}	5	V
Collector Current	I_{C}	500	mA
Base Current	I_{B}	100	mA
Power Dissipation	P_{tot}	500	mW
Junction Temperature	T_{j}	150	$^\circ\text{C}$
Storage Temperature Range	T_{stg}	- 55 to + 150	$^\circ\text{C}$

Thermal Characteristics

Parameter	Symbol	Max.	Unit
Thermal Resistance from Junction to Ambient	$R_{\theta\text{JA}}$	250	$^\circ\text{C}/\text{W}$

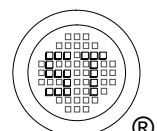

2SC1959

Characteristics at $T_a = 25^\circ\text{C}$

Parameter	Symbol	Min.	Typ.	Max.	Unit	
DC Current Gain at $V_{CE} = 1\text{ V}$, $I_C = 100\text{ mA}$ at $V_{CE} = 6\text{ V}$, $I_C = 400\text{ mA}$	Current Gain Group O	h_{FE}	70	-	140	-
	Y	h_{FE}	120	-	240	-
	G	h_{FE}	200	-	400	-
		h_{FE}	25	-	-	-
Collector Base Cutoff Current at $V_{CB} = 35\text{ V}$	I_{CBO}	-	-	0.1	μA	
Emitter Base Cutoff Current at $V_{EB} = 5\text{ V}$	I_{EBO}	-	-	0.1	μA	
Collector Base Breakdown Voltage at $I_C = 100\text{ }\mu\text{A}$	$V_{(BR)CBO}$	35	-	-	V	
Collector Emitter Breakdown Voltage at $I_C = 10\text{ mA}$	$V_{(BR)CEO}$	30	-	-	V	
Emitter Base Breakdown Voltage at $I_E = 10\text{ }\mu\text{A}$	$V_{(BR)EBO}$	5	-	-	V	
Collector Emitter Saturation Voltage at $I_C = 100\text{ mA}$, $I_B = 10\text{ mA}$	$V_{CE(sat)}$	-	0.1	0.25	V	
Base Emitter Voltage at $I_C = 100\text{ mA}$, $V_{CE} = 1\text{ V}$	V_{BE}	-	0.8	1	V	
Transition Frequency at $V_{CE} = 6\text{ V}$, $I_C = 20\text{ mA}$	f_T	-	300	-	MHz	
Output Capacitance at $V_{CB} = 6\text{ V}$, $f = 1\text{ MHz}$	C_{ob}	-	4	-	pF	

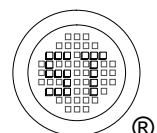

Electrical Characteristics Curves

Fig. 1 Output Characteristics Curve

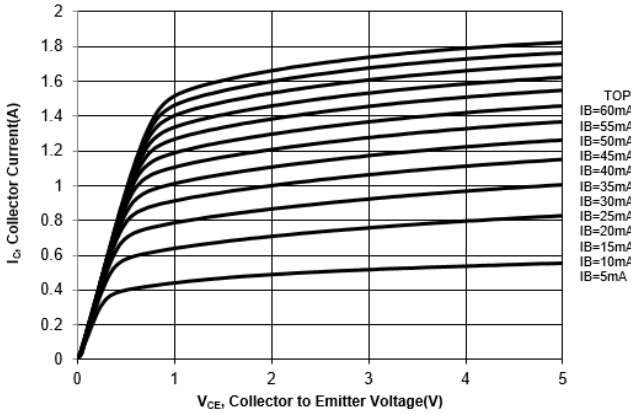

Fig. 2 Collector Current vs. Base to Emitter Voltage

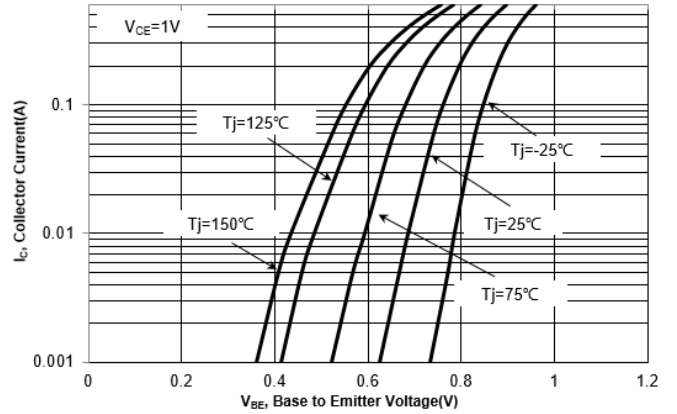

Fig. 3 DC Current Gain vs. Collector Current

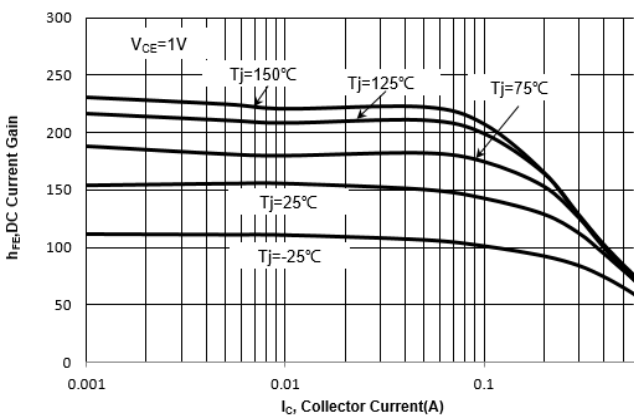
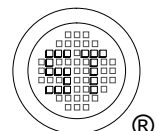
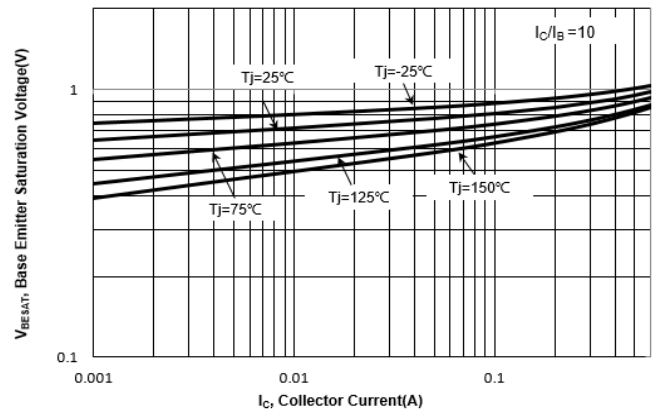

Fig. 4 V_{BESAT} vs. Collector Current



Electrical Characteristics Curves

Fig. 5 V_{CESAT} vs. Collector Current

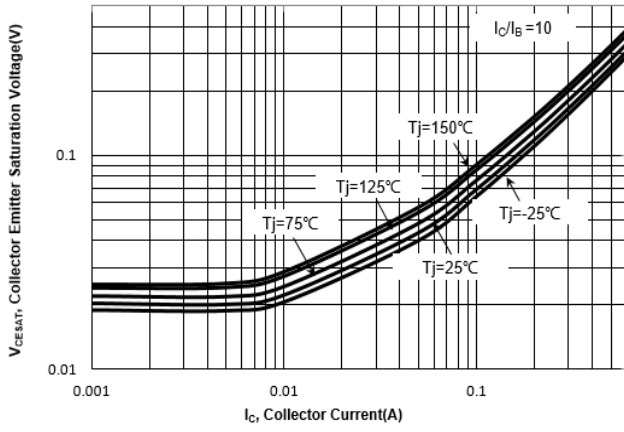

Fig. 6 Output Capacitance

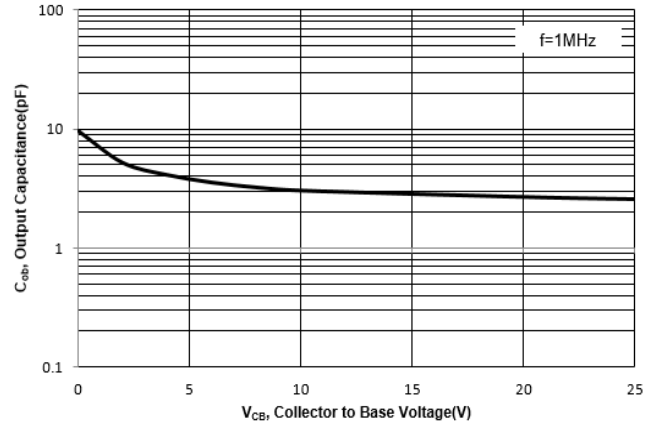
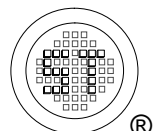
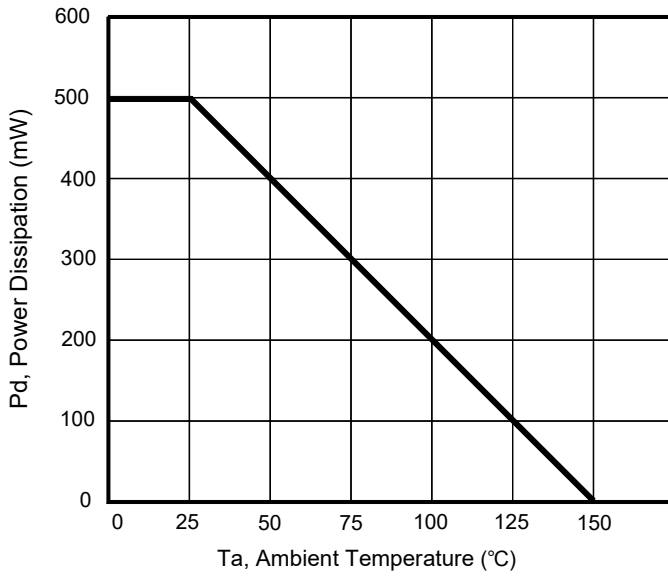
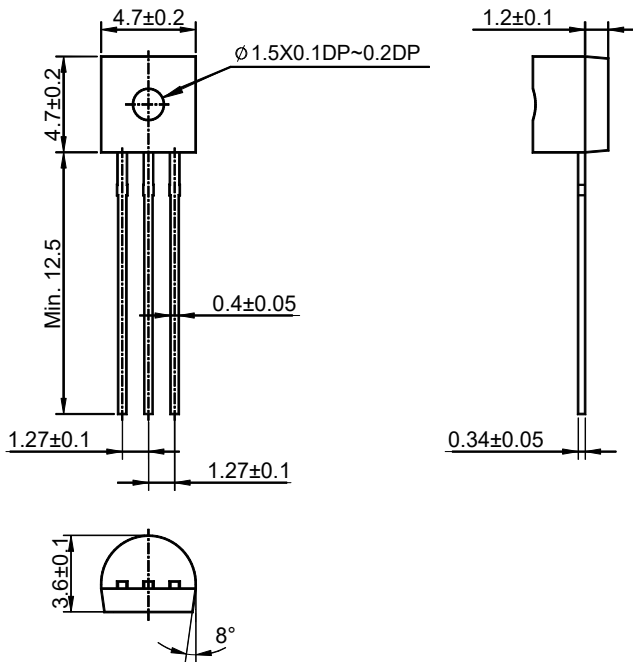

Fig 7. Power Derating Curve



2SC1959

TO-92 Package Outline (Dimensions in millimeters)



TO-92 Ammo-Pack Outline (Dimensions in millimeters)

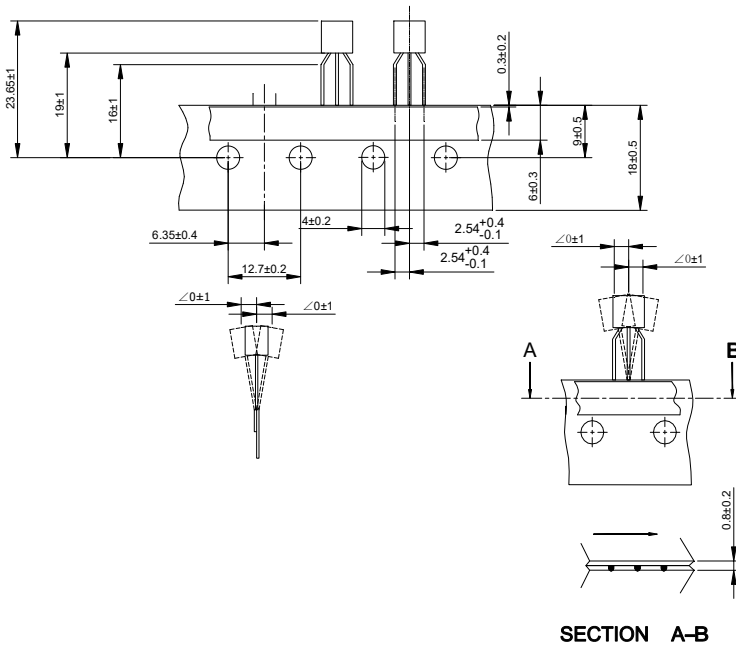

SECTION A-B

Packing information

Package	Bulk Packing			Ammo-Packing	
	Per Bag Qty	Per Box Qty	Per Carton Qty	Per Box Qty	Per Carton Qty
TO-92	1,000	5,000	50,000	4,000	20,000

