

# 2SC1674

## NPN Silicon Epitaxial Planar Transistor

### Features

- The transistor is subdivided into three groups, R, O, and Y, according to its DC current gain
- On special request, these transistors can be manufactured in different pin configurations.

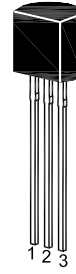

1. Emitter 2. Collector 3. Base  
TO-92 Plastic Package

### Applications

- For TV PIF amplifier, FM tuner RF amplifier

### Absolute Maximum Ratings ( $T_a = 25\text{ }^\circ\text{C}$ )

Parameter	Symbol	Value	Unit
Collector Base Voltage	$V_{CBO}$	30	V
Collector Emitter Voltage	$V_{CEO}$	20	V
Emitter Base Voltage	$V_{EBO}$	4	V
Collector Current	$I_C$	20	mA
Power Dissipation	$P_{tot}$	250	mW
Junction Temperature	$T_j$	150	$^\circ\text{C}$
Storage Temperature Range	$T_{stg}$	- 55 to + 150	$^\circ\text{C}$

### Thermal Characteristics

Parameter	Symbol	Max.	Unit
Thermal Resistance from Junction to Ambient	$R_{\theta JA}$	500	$^\circ\text{C/W}$

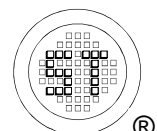

# 2SC1674

## Characteristics at $T_a = 25\text{ }^\circ\text{C}$

Parameter	Symbol	Min.	Typ.	Max.	Unit	
DC Current Gain at $V_{CE} = 6\text{ V}$ , $I_C = 1\text{ mA}$	Current Gain Group R O Y	$h_{FE}$	40	-	80	-
		$h_{FE}$	70	-	140	-
		$h_{FE}$	120	-	240	-
Collector Base Cutoff Current at $V_{CB} = 30\text{ V}$	$I_{CBO}$	-	-	100	nA	
Emitter Base Cutoff Current at $V_{EB} = 4\text{ V}$	$I_{EBO}$	-	-	100	nA	
Collector Base Breakdown Voltage at $I_C = 10\text{ }\mu\text{A}$	$V_{(BR)CBO}$	30	-	-	V	
Collector Emitter Breakdown Voltage at $I_C = 5\text{ mA}$	$V_{(BR)CEO}$	20	-	-	V	
Emitter Base Breakdown Voltage at $I_E = 10\text{ }\mu\text{A}$	$V_{(BR)EBO}$	4	-	-	V	
Collector Emitter Saturation Voltage at $I_C = 10\text{ mA}$ , $I_B = 1\text{ mA}$	$V_{CE(sat)}$	-	-	0.3	V	
Gain Bandwidth Product at $V_{CE} = 6\text{ V}$ , $I_C = 1\text{ mA}$	$f_T$	-	600	-	MHz	
Output Capacitance at $V_{CB} = 6\text{ V}$ , $f = 1\text{ MHz}$	$C_{ob}$	-	0.7	-	pF	

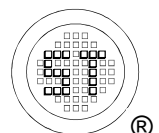

# 2SC1674

## Electrical Characteristics Curves

Fig. 1 Output Characteristics Curve

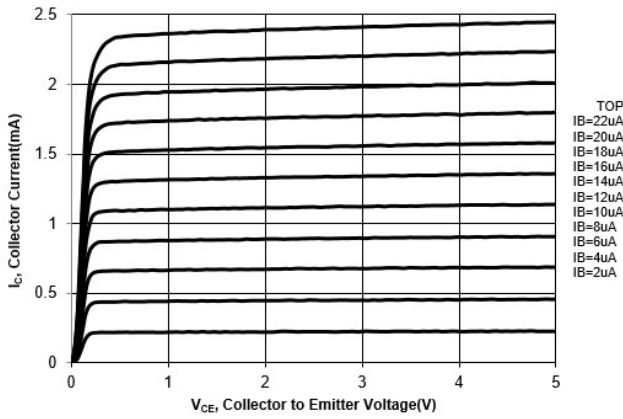

Fig. 2 Collector Current vs. Base to Emitter Voltage

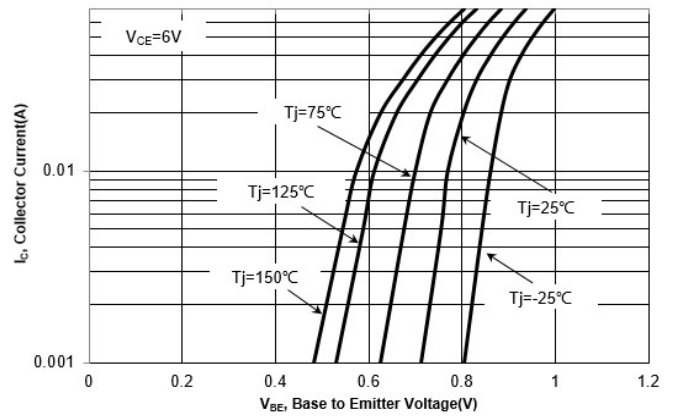

Fig. 3 DC Current Gain vs. Collector Current

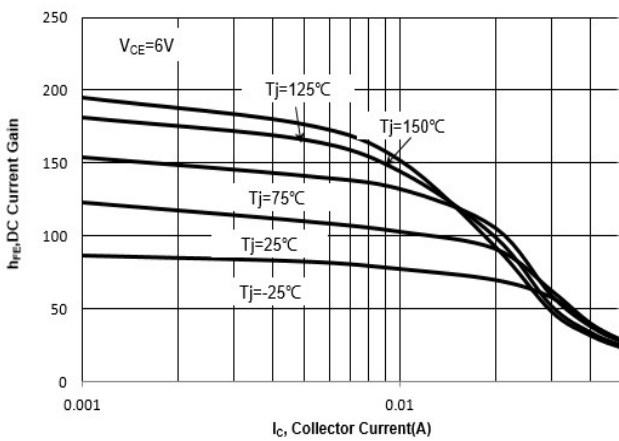
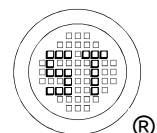
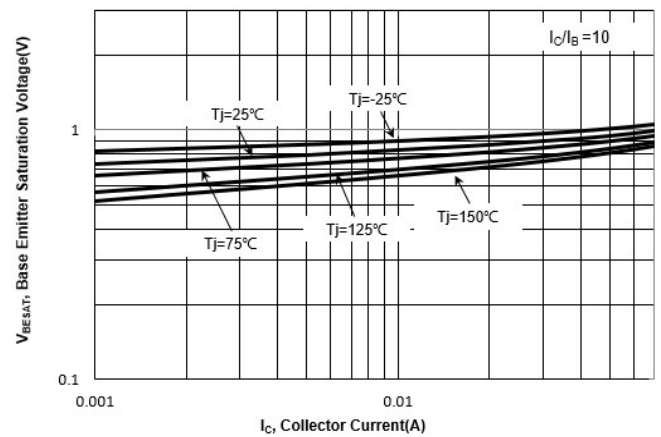

Fig. 4  $V_{BESAT}$  vs. Collector Current



# 2SC1674

## Electrical Characteristics Curves

Fig. 5  $V_{CESAT}$  vs. Collector Current

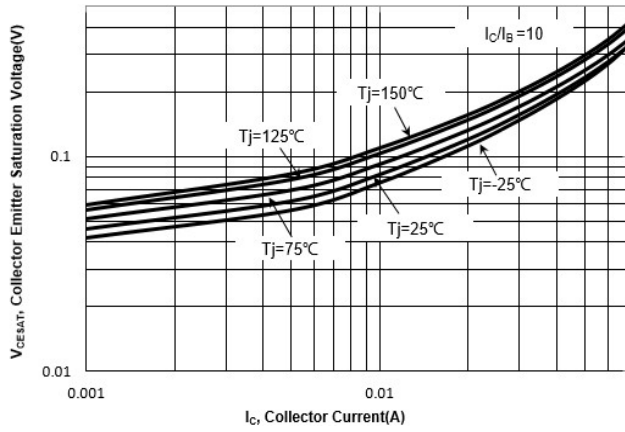

Fig. 6 Output Capacitance

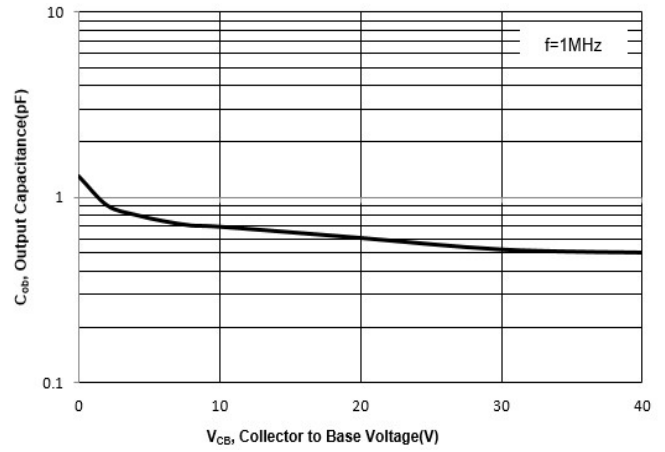
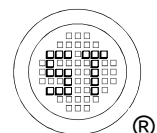
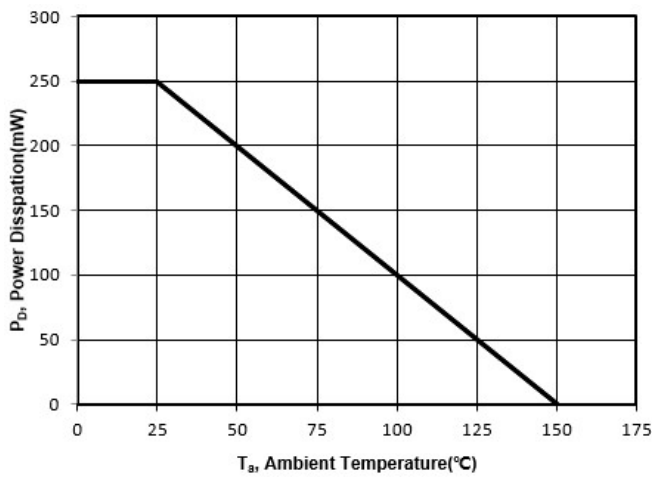
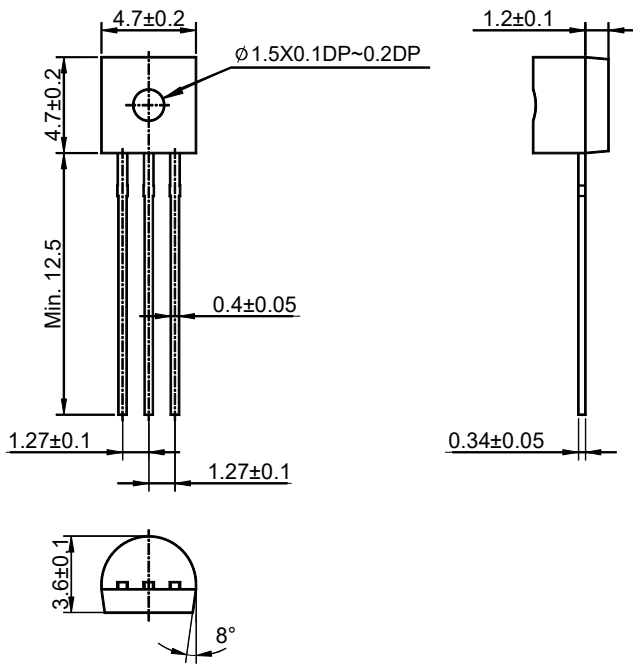

Fig. 7 Power Derating Curve



# 2SC1674

## TO-92 Package Outline (Dimensions in millimeters)



## TO-92 Ammo-Pack Outline (Dimensions in millimeters)

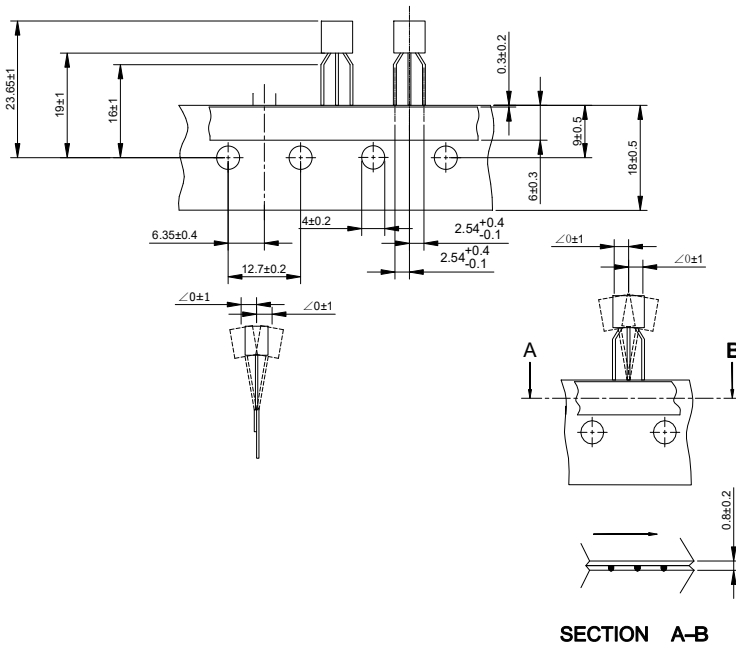

SECTION A-B

## Packing information

Package	Bulk Packing			Ammo-Packing	
	Per Bag Qty	Per Box Qty	Per Carton Qty	Per Box Qty	Per Carton Qty
TO-92	1,000	5,000	50,000	4,000	20,000

