

2SA1662U

PNP Silicon Epitaxial Planar Transistor

Applications

- General purpose application

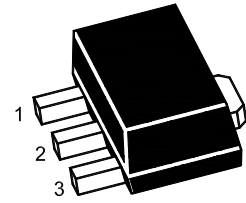

1.Base 2.Collector 3.Emitter
SOT-89 Plastic Package

Absolute Maximum Ratings ($T_a = 25^\circ\text{C}$)

Parameter	Symbol	Value	Unit
Collector Base Voltage	$-V_{\text{CBO}}$	80	V
Collector Emitter Voltage	$-V_{\text{CEO}}$	80	V
Emitter Base Voltage	$-V_{\text{EBO}}$	5	V
Collector Current	$-I_{\text{C}}$	400	mA
Base Current	$-I_{\text{B}}$	80	mA
Total Power Dissipation	P_{tot}	0.5 ¹⁾ 1 ²⁾	W
Junction Temperature	T_{j}	150	$^\circ\text{C}$
Storage Temperature Range	T_{stg}	- 55 to + 150	$^\circ\text{C}$

Thermal Characteristics

Parameter	Symbol	Max.	Unit
Thermal Resistance from Junction to Ambient	$R_{\theta\text{JA}}$	250 ¹⁾ 125 ²⁾	$^\circ\text{C/W}$

¹⁾ Device mounted on FR-4 substrate PC board, 2oz copper, with minimum recommended pad layout.

²⁾ Device mounted on FR-4 substrate PC board, 2oz copper, with 1-inch square copper plate.

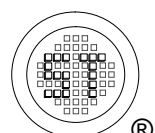

2SA1662U

Characteristics at $T_a = 25^\circ\text{C}$

Parameter	Symbol	Min.	Typ.	Max.	Unit	
DC Current Gain at $-V_{CE} = 2\text{ V}$, $-I_C = 50\text{ mA}$ at $-V_{CE} = 2\text{ V}$, $-I_C = 200\text{ mA}$	Current Gain Group O Y	h_{FE}	70	-	140	-
		h_{FE}	120	-	240	-
		h_{FE}	40	-	-	-
Collector Base Cutoff Current at $-V_{CB} = 80\text{ V}$	$-I_{CBO}$	-	-	100	nA	
Emitter Base Cutoff Current at $-V_{EB} = 5\text{ V}$	$-I_{EBO}$	-	-	100	nA	
Collector Base Breakdown Voltage at $-I_C = 100\text{ }\mu\text{A}$	$-V_{(BR)CBO}$	80	-	-	V	
Collector Emitter Breakdown Voltage at $-I_C = 10\text{ mA}$	$-V_{(BR)CEO}$	80	-	-	V	
Emitter Base Breakdown Voltage at $-I_E = 100\text{ }\mu\text{A}$	$-V_{(BR)EBO}$	5	-	-	V	
Collector Emitter Saturation Voltage at $-I_C = 200\text{ mA}$, $-I_B = 20\text{ mA}$	$-V_{CE(sat)}$	-	-	0.4	V	
Base Emitter on Voltage at $-V_{CE} = 2\text{ V}$, $-I_C = 5\text{ mA}$	$-V_{BE(on)}$	0.55	-	0.8	V	
Transition Frequency at $-V_{CE} = 10\text{ V}$, $-I_C = 10\text{ mA}$	f_T	-	120	-	MHz	
Collector Output Capacitance at $-V_{CB} = 10\text{ V}$, $f = 1\text{ MHz}$	C_{ob}	-	5	-	pF	

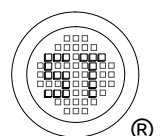

2SA1662U

Electrical Characteristics Curves

Fig. 1 Output Characteristics Curve

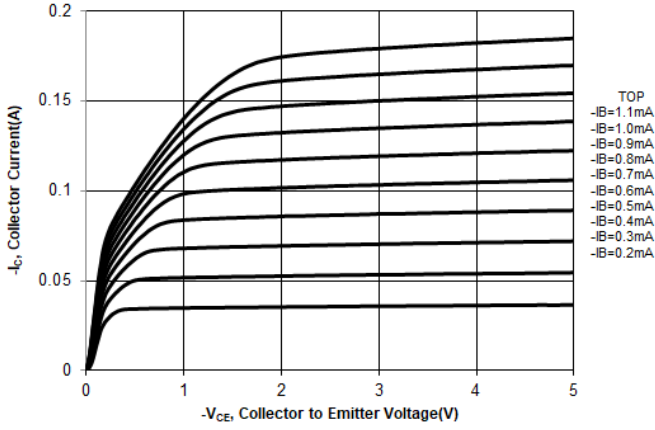

Fig. 2 Collector Current vs. Base to Emitter Voltage

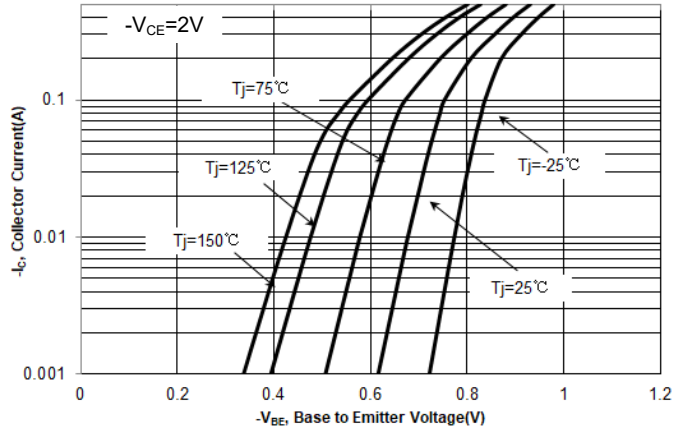

Fig. 3 DC Current Gain vs. Collector Current

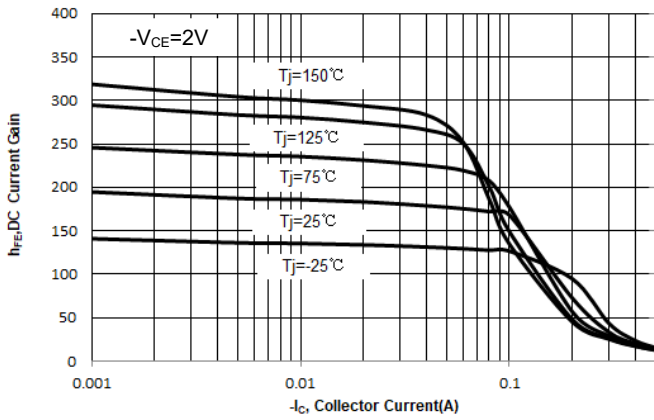
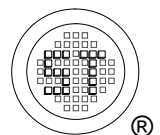
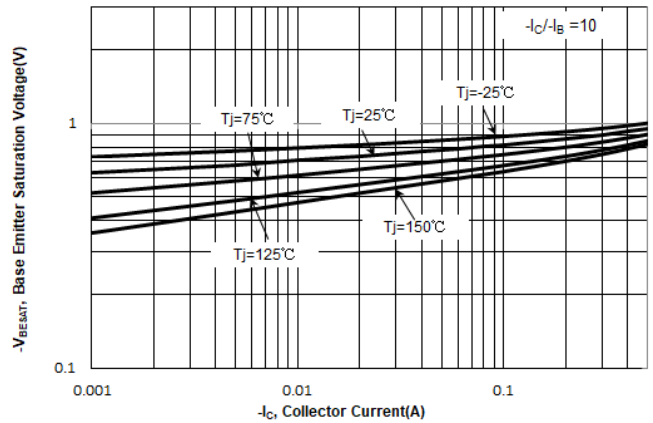

Fig. 4 $V_{BE(sat)}$ vs. Collector Current



2SA1662U

Electrical Characteristics Curves

Fig. 5 $V_{CE(sat)}$ vs. Collector Current

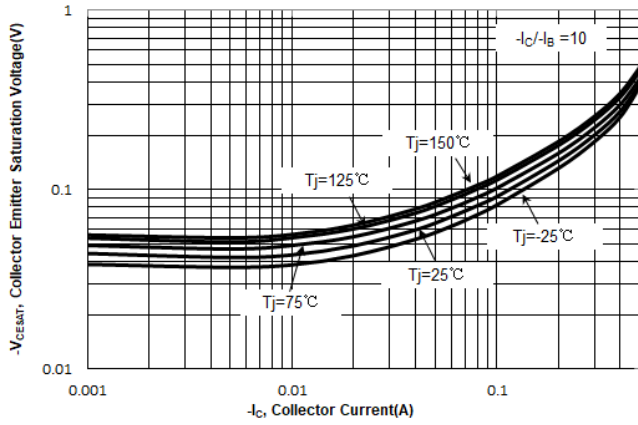

Fig. 6 Junction Capacitance

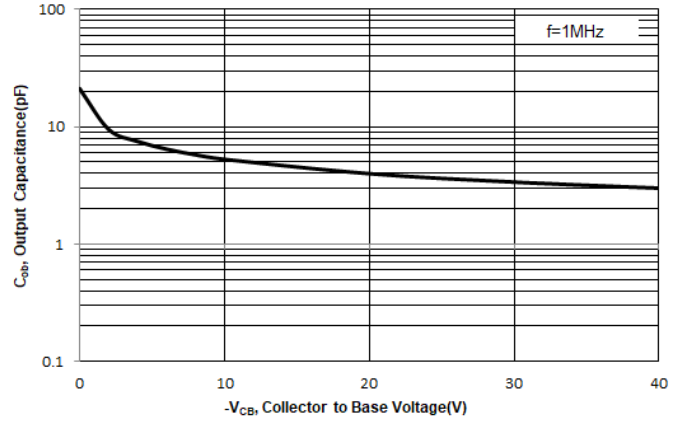
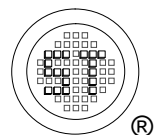
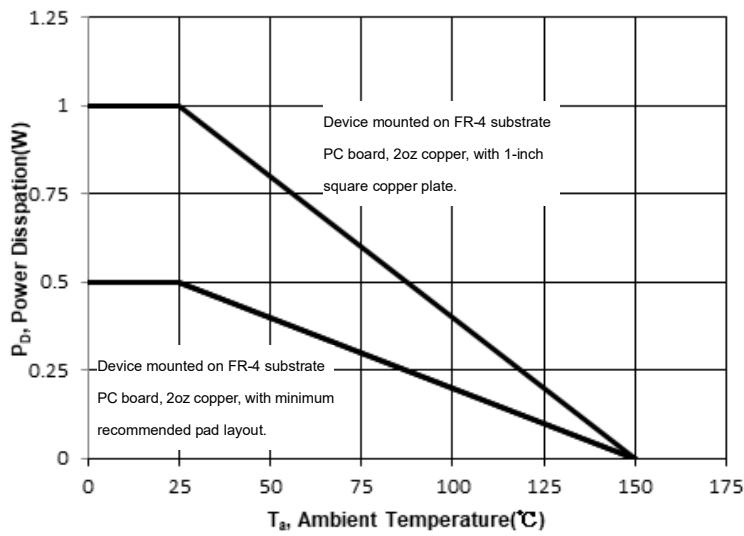

Fig. 7 Power Derating Curve



2SA1662U

Package Outline (Dimensions in mm)

SOT-89

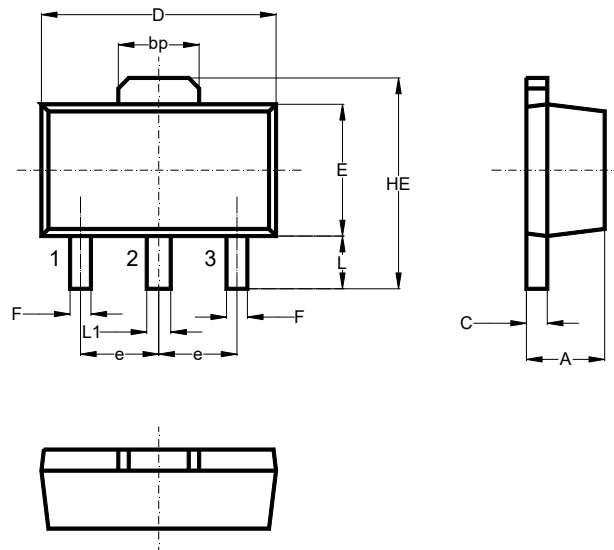

Unit	A	bp	C	D	E	F	HE	e	L	L1
mm	1.6	1.60	0.5	4.6	2.6	0.45	4.25	1.5	1.05	0.51
	1.4	1.50	0.3	4.4	2.4	0.35	3.75	typ.	0.95	0.41

Recommended Soldering Footprint

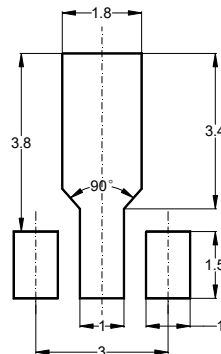

Packing information

Package	Tape Width (mm)	Pitch		Reel Size		Per Reel Packing Quantity
		mm	inch	mm	inch	
SOT-89	12	8 ± 0.1	0.315 ± 0.004	178	7	1,000

Marking information

"2SA1662*U" = Part No. ("*" = HFE grouping Code)

"YM" = Date Code Marking

"Y" = Year

"M" = Month

Font type: Arial

