

13002MQ-HAF

NPN Silicon Epitaxial Planar Power Transistor

Features

- Low Collector Emitter Saturation Voltage
- Halogen and Antimony Free(HAF), RoHS compliant

Applications

- Audio output amplifier
- Power switching applications

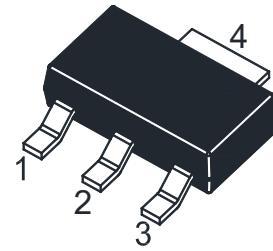

1.Base 2.Collector 3.Emitter 4.Collector
SOT-223 Plastic Package

Absolute Maximum Ratings ($T_a = 25^\circ\text{C}$)

Parameter	Symbol	Value	Unit
Collector Base Voltage	V_{CBO}	600	V
Collector Emitter Voltage	V_{CEO}	400	V
Emitter Base Voltage	V_{EBO}	6	V
Collector Current	I_C	1	A
Peak Collector Current, Pulesd	I_{CM}	2	A
Power Dissipation	P_{tot}	1.25	W
Operating Junction and Storage Temperature Range	T_j, T_{stg}	- 55 to + 150	$^\circ\text{C}$

Thermal Characteristics

Parameter	Symbol	Value	Unit
Thermal Resistance from Junction to Ambient ¹⁾	$R_{\theta JA}$	100	$^\circ\text{C/W}$

¹⁾ Device mounted on FR-4 substrate PC board, 2oz copper, with 1-inch square copper plate.

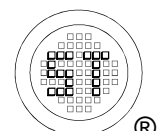

13002MQ-HAF

Characteristics at $T_a = 25^\circ\text{C}$

Parameter	Symbol	Min.	Max.	Unit
DC Current Gain at $V_{CE} = 5\text{ V}$, $I_C = 100\text{ mA}$	h_{FE}	15	30	-
Collector Base Cutoff Current at $V_{CB} = 600\text{ V}$	I_{CBO}	-	10	μA
Collector Emitter Cutoff Current at $V_{CE} = 400\text{ V}$	I_{CEO}	-	100	μA
Emitter Base Cutoff Current at $V_{EB} = 6\text{ V}$	I_{EBO}	-	10	μA
Collector Base Breakdown Voltage at $I_C = 100\text{ }\mu\text{A}$	$V_{(BR)CBO}$	600	-	V
Collector Emitter Breakdown Voltage at $I_C = 1\text{ mA}$	$V_{(BR)CEO}$	400	-	V
Emitter Base Breakdown Voltage at $I_E = 100\text{ }\mu\text{A}$	$V_{(BR)EBO}$	6	-	V
Collector Emitter Saturation Voltage at $I_C = 500\text{ mA}$, $I_B = 100\text{ mA}$	$V_{CE(sat)}$	-	0.5	V
Base Emitter Saturation Voltage at $I_C = 500\text{ mA}$, $I_B = 100\text{ mA}$	$V_{BE(sat)}$	-	1.5	V
Base Emitter Turn-On Voltage at $V_{CE} = 10\text{ V}$, $I_C = 1\text{ A}$	$V_{BE(on)}$	-	1.5	V
Current Gain Bandwidth Product at $V_{CE} = 10\text{ V}$, $I_C = 100\text{ mA}$, $f = 1\text{ MHz}$	f_T	5	-	MHz

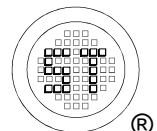

13002MQ-HAF

Electrical Characteristics Curves

Fig. 1 Output Characteristics Curve

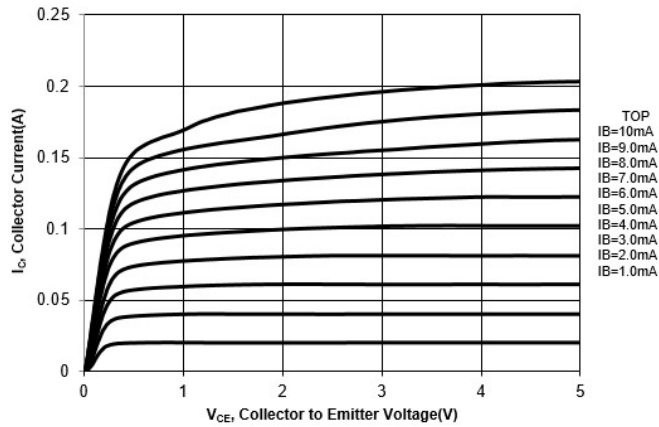

Fig. 2 Collector Current vs. Base to Emitter Voltage

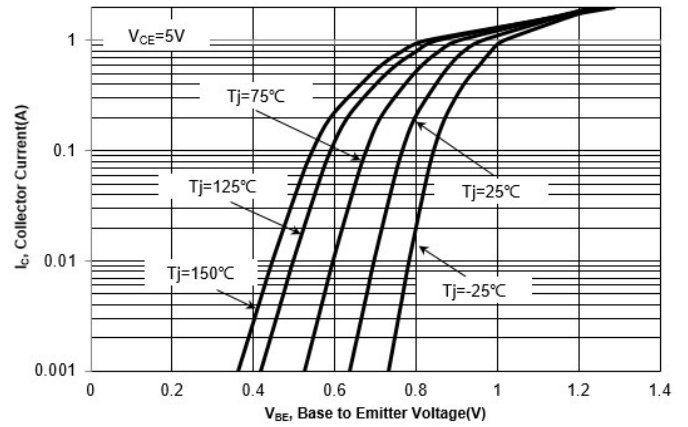

Fig. 3 DC Current Gain vs. Collector Current

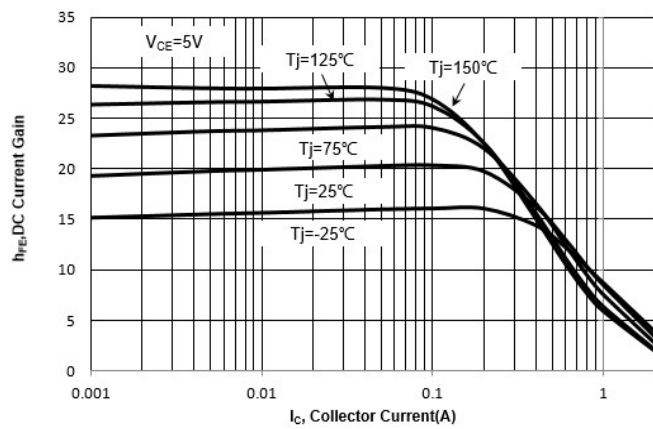
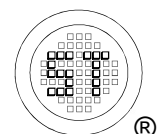
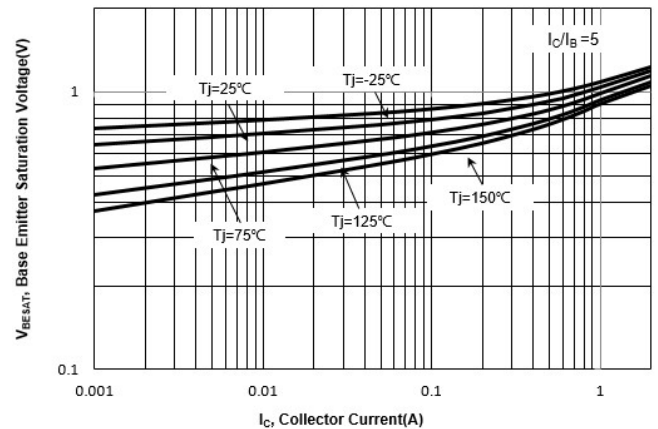

Fig. 4 V_{BESAT} vs. Collector Current



Electrical Characteristics Curves

Fig. 5 V_{CESAT} vs. Collector Current

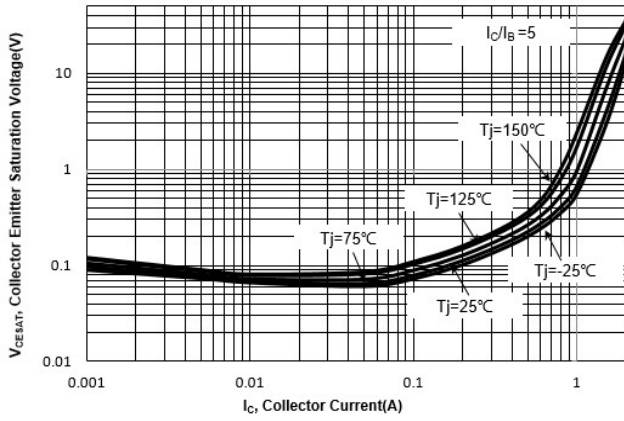

Fig. 6 Output Capacitance

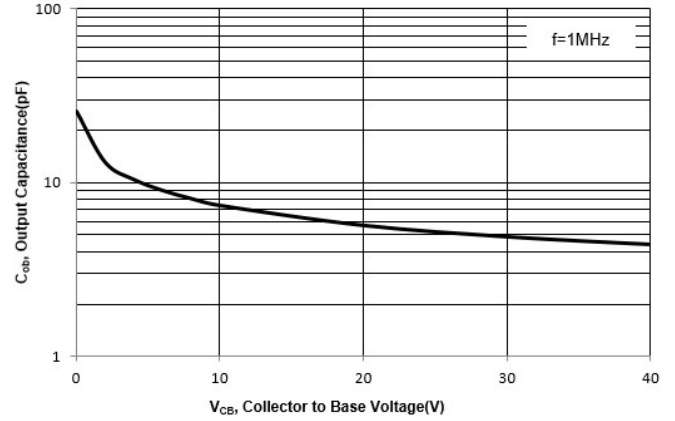
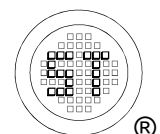
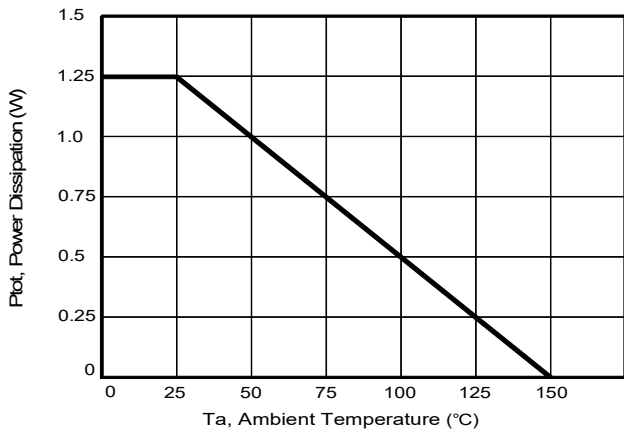

Fig. 7 Power Derating Curve



13002MQ-HAF

Package Outline (Dimensions in mm)

SOT-223

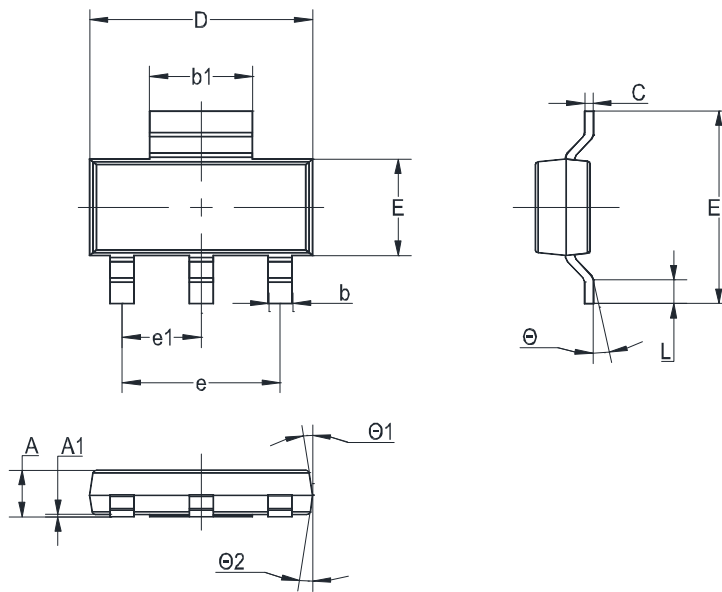

Unit	A	A1	b	b1	C	D	E	E1	e	e1	L	Θ	Θ1	Θ2
mm	1.8	0.1	0.8	3.1	0.32	6.7	3.7	7.3	4.6	2.3	1.1	10°	7°	7°
	1.5	MAX	0.6	2.9	0.22	6.3	3.3	6.7	TYP	TYP	0.7	0°	0°	0°

Recommended Soldering Footprint

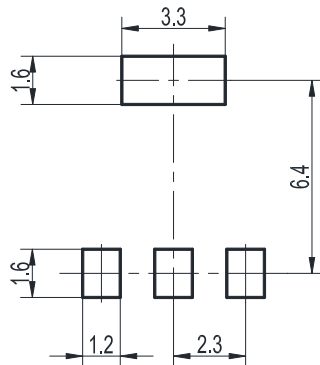

Packing information

Package	Tape Width (mm)	Pitch		Reel Size		Per Reel Packing Quantity
		mm	inch	mm	inch	
SOT-223	12	8 ± 0.1	0.315 ± 0.004	330	13	3,000

Marking information

" 13002MQ " = Part No.

" ***** " = Date Code Marking

Font type: Arial

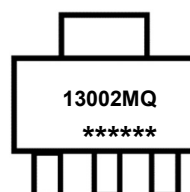

Disclaimer: Our company reserve the right to make modifications, enhancements, improvements, corrections or other changes to improve product design, functions and reliability, anytime without notice. Semtech Electronics Limited makes no warranties, representations or warranties regarding the suitability of its products for any particular purpose, and does not accept any liability arising from the application or use of any product or circuit such as: Apply to medical, military, aircraft, space or life support equipment and expressly waive any and all liability, including but not limited to special, consequential or collateral damage.

